

FURUNO

OPERATOR'S MANUAL

ECHO SOUNDER

MODEL FE-808



FURUNO ELECTRIC CO., LTD.
NISHINOMIYA, JAPAN

©FURUNO ELECTRIC CO., LTD.

9-52, Ashihara-cho,
Nishinomiya, Japan 662

Telephone: 0798-65-2111
Telefax: 0798-65-4200

All rights reserved.

Printed in Japan

(TAMI)

PUB. No. OME-22850
FE-808

-Your Local Agent/Dealer

FIRST EDITION : DEC 1983
D : NOV. 0, 1988



00080667600

C O N T E N T S

* * * * *

	<u>Page</u>
FEATURES OF FE-808	0-1
OPERATION	1-1 to 1-6
1. Operating Controls and Switches	1-1
2. Paper Loading	1-5
HOW TO INTERPRET ECHOGRAM	2-1 to 2-9
What is provided on echogram	2-1
Variety of echogram with echo sounder characteristics	2-2
To read more from echogram	2-5
MAINTENANCE	3-1 to 3-2
1. Stylus Replacement and Adjustment	3-1
2. Fuse Replacement	3-2
3. Cleaning	3-2
TROUBLESHOOTING	4-1 to 4-2
Appendix 1. Specifications	AP1-1 to AP1-3
Appendix 2. Installation	AP2-1 to AP2-10
Appendix 3. How to change calibration unit	AP3-1
SCHEMATIC DIAGRAMS	S-1 to S-4

FEATURES OF FE-808

* * * * *

The FE-808, with FURUNO's years of experience in commercial echo sounders, adds many advantageous features to conventional echo sounders.

Thanks to new electronic devices and advanced digital signal processing technique, it provides fine and distinct recording of underwater objects. Aside its high quality recording, remarkable features of FE-808 are as follows.

- * Shaded recording by light-gray, gray and black gradation facilitates to know fish concentration and seabed nature.
- * Two-step expanded bottom-lock recording, which is extremely useful in bottom trawling or in shell fish finding, is available together with normal recording.
- * A bright digital display provides seabed depth at a glance together with start and end depth.
- * Extremely effective noise limiter without any effect on wanted echoes.
- * Three kinds of mount types, i.e. flush mount, bulkhead mount and table-top mount, are selectable.

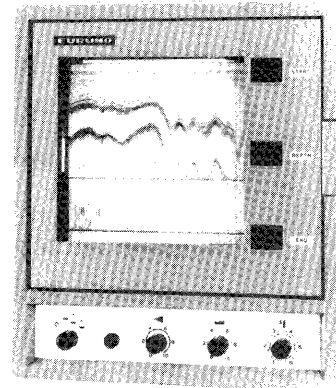

F Photo No.1307 PC

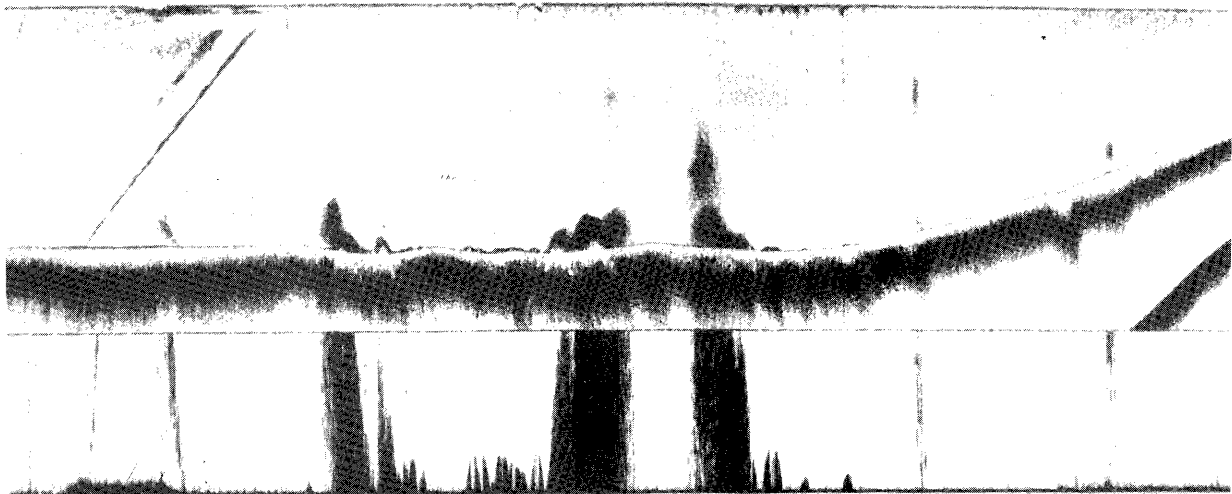

We hope you will read the following instructions and make best use of your FE-808.

(By adding slight modification, signals detected by the FE-808 can be displayed on FURUNO'S FCV-120/200 Color Video Sounder and even recorded into MT-11/12 Picture Recorder. Refer to "VI-1100A Installation Manual".)

OPERATION

* * * * *

1. Operating Controls and Switches

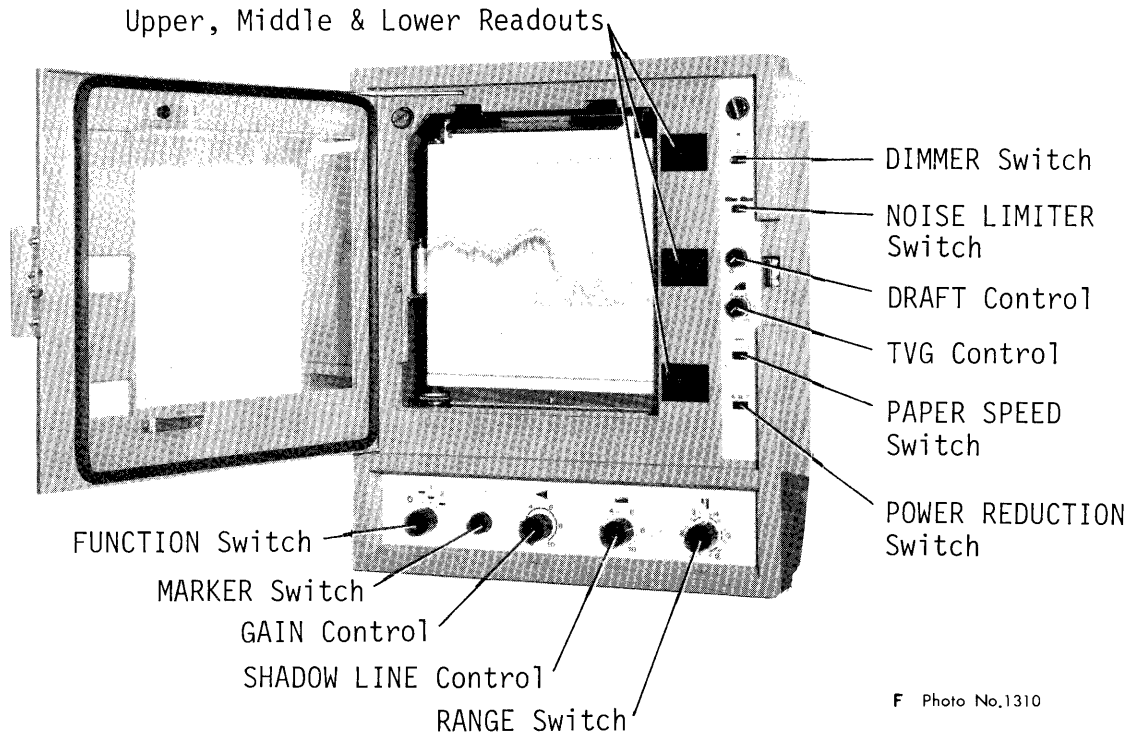

[FRONT PANEL CONTROLS]

FUNCTION Switch

This switch has two functions: power on-off and selection of recording modes.

The position "O" shuts off the power of the set. Use this position to stop recording or to load new paper.

Turning this switch to "■" (normal) provides normal recording over the full paper width.

Turning this to "1" or "2" (bottom-lock) provides compressed normal recording on the upper 2/3 of paper width and an expanded bottom-lock recording on the rest. The **SHADOW LINE** control must be adjusted properly to ensure stable bottom-lock recording. The bottom-lock range is 5m (7.5ft or 2.5fam/braza/passi) or 10m (15ft or 2.5fam/braza/passi) at "1" or "2" respectively.

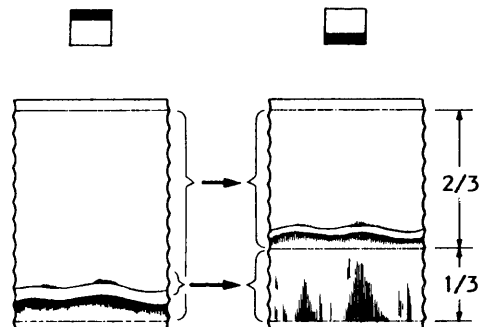
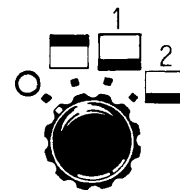

MARKER Switch

Press this button, and a straight line appears across the paper. It is used to examine the condition of the recording stylus or belt, and also to mark an event position.

GAIN Control

Turning this clockwise increases the sensitivity of the receiver. Use higher gain for deep sea operations, and lower gain in shallow waters.

The table at right gives general guidelines for gain settings on range chosen and frequency of operation.

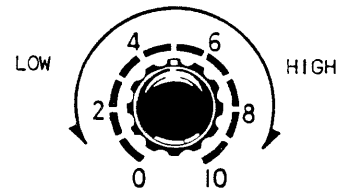

RANGE	GAIN		
	28kHz	50kHz	200kHz
1	1 to 3	2 to 3	2 to 4
2	2 to 4	3 to 4	3 to 5
3	3 to 5	4 to 5	4 to 6
4-6	5 to 10		

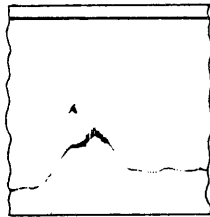

GAIN too low



GAIN optimum



GAIN too high

SHADOW LINE Control

This control is used for discriminating fish or other targets just above the seabed. (This function is also known as "whiteline" or "grayline" in other machines.)

After the GAIN control has been adjusted (with the SHADOW LINE off) for a good bottom recording, turn the SHADOW LINE control slowly clockwise to give a gray "shadow" just under the top of the seabed echo. Now fish will show distinctly above the seabed even if they close to the bottom.

Too far a clockwise setting of this control can blank fish echoes, and the correct depth reading or bottom-lock operation may be affected.

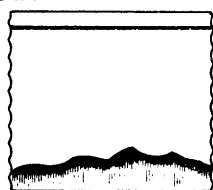
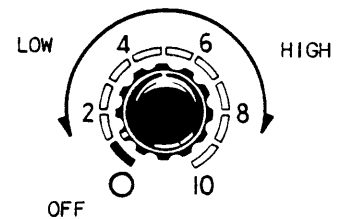

SHADOW LINE "OFF"

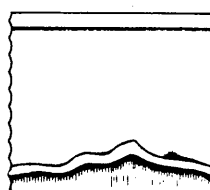

SHADOW LINE optimum

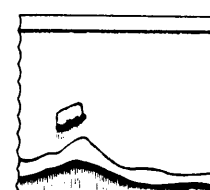

SHADOW LINE too high

RANGE Switch

This selects the depth range to be recorded on the paper. The basic range is doubled step-by-step by turning it from 1 to 6. The "b" position on each range is a 50%-phased range with respect to the basic "a" range. Refer to table below.

BASIC PHASED	1		2		3		4		5		6	
	a	b	a	b	a	b	a	b	a	b	a	b
Meters	0 20	10 30	0 40	20 60	0 80	40 120	0 100	100 300	0 400	200 600	0 800	400 1200
Feet	0 30	15 45	0 60	30 90	0 120	60 180	0 300	150 450	0 600	300 900	0 1200	600 1800
Fathoms Brazas Passis	0 10	5 15	0 20	10 30	0 40	20 60	0 100	50 150	0 200	100 300	0 400	200 600

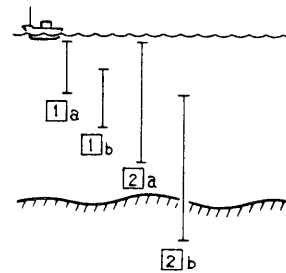
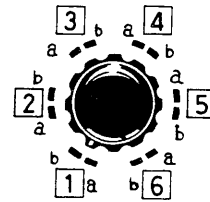

Upper, Middle & Lower Readouts

With the SHADOW LINE control at "O" (off) position, the upper and lower readouts show the start and end depths of the recording range selected by the RANGE switch. The middle readout shows nothing.

With the SHADOW LINE control turned clockwise, the middle readout shows the seabed depth. The upper and lower readouts show the depth range as before.

However, if there is strong interference from other echo sounders nearby or if a very dense fish school is encountered, the seabed depth reading may become unstable momentarily. This condition may mean that excessive Shadow Line/Gain is used.

Two decimal points on the middle readout are used as alarm indicator.

The one on the left is an "overflow" indicator that lights when the reading has gone over "999". This may happen in deep water operation.

Note: This indicator may light when power is applied with the SHADOW LINE "off". If so, turn it on and off once.

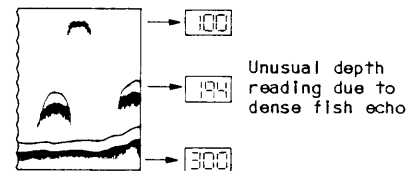
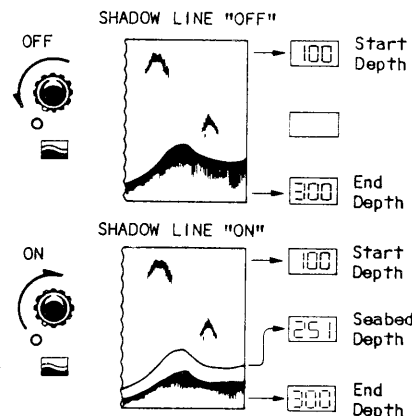

Middle Readout

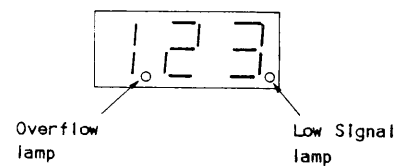

Ex. "1.23" ---- 1123(feet)

Ex. "123." ---- Reading not reliable.

The one on the right is a "low signal" indicator that flickers when the signal is too weak to allow proper shadow line operation. This is to alert that the seabed depth shown on the middle readout may not be reliable.

Note: When the SHADOW LINE control is set at off, the indicator flickers.

When the RANGE switch is set to 6b(meter), 6a(feet) or 6b(feet), the lower readout shows as 1200(1200m, 1200ft) or 1800(1800ft) respectively.

[SUB-PANEL CONTROLS]

- inside the front door -

DIMMER Switch

This switch has three positions, i.e. dim (1), medium (2) and bright (3) to control the illumination of the recording paper and control panel as well as brightness of LED displays.

NOISE LIMITER Switch

With this switch turned to " , random interference or noise can be minimized. As it may reduce sensitivity for small targets, it is recommended to turn it off if noise is not perceivable.

DRAFT Control

This adjusts the position of zero line on the paper. The primary purpose of this control is to read the true depth from sea surface, taking the ship's draft into account.

This may also be used to shift the recording area downward to use the paper twice or more times. However, the following points should be noted.

- a. This method does not work on the phased ("b") ranges.
- b. Multiple recording may be confusing to read.

TVG Control

The TVG control is used to compensate for the effect of propagation loss of sound energy in water, suppressed gain just after transmission, and increasing gain as time (range) elapses. Too far a clockwise setting will miss weak targets in shallow/mid water.

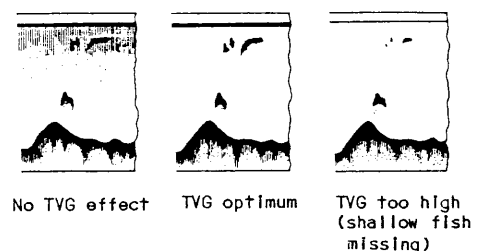
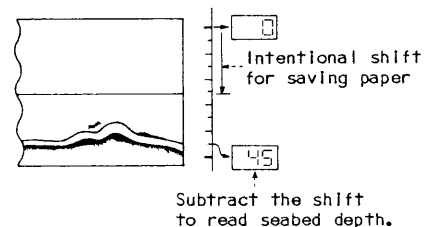
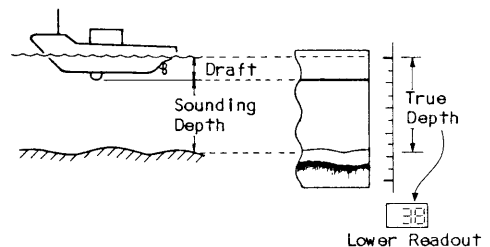
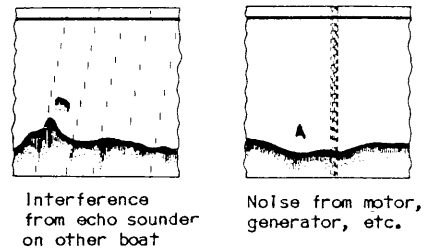

PAPER SPEED Switch

1 2 3

This selects the paper sending speed. Select the optimum speed, taking depth range and ship's speed into account. A guideline for paper speed setting is shown at right. Refer to specifications on page AP1-1 for actual paper speed.

RANGE	SPEED
1, 2, 3	3 (Fast)
4, 5	2 (Medium)
6	1 (Slow)

POWER REDUCTION Switch

This selects the output power of the sounding pulse. Use high power at position "C" for normal use. Occasionally low power at "A" position is needed in extremely shallow water, or on congested fishing grounds to minimize interference to other boats.

2. Paper Loading

During operation, an end mark will eventually appear on the bottom of the paper. This is to warn that the paper is running out, and you will need a new roll of paper soon.

Change the paper roll, following the procedure below.

1. Turn the FUNCTION switch to "O" (off).
2. Open the front door.
3. Swing the recorder assembly down by holding the catch tabs after confirming that the recording stylus is behind the recording plate.
4. Pull down the paper holder flaps and remove the used paper and spools.
5. Put a new roll of paper into the feed holder and an empty spool into the take-up holder. Then pass the paper over the recording plate and insert the end into the spool slot, or tape the end squarely to the spool.

Roll the paper 3 to 4 turns so that it will not come loose.

6. Carefully swing up and push the recorder assembly backwards until you feel a click at the catch tabs.
7. Turn the thumb roller to smooth out the paper over the recording plate.
8. Close the front door again.

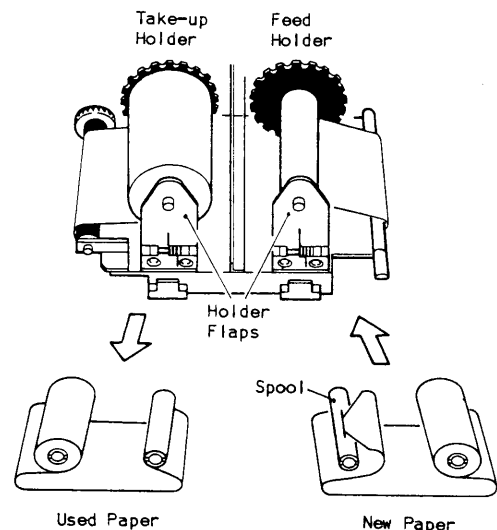
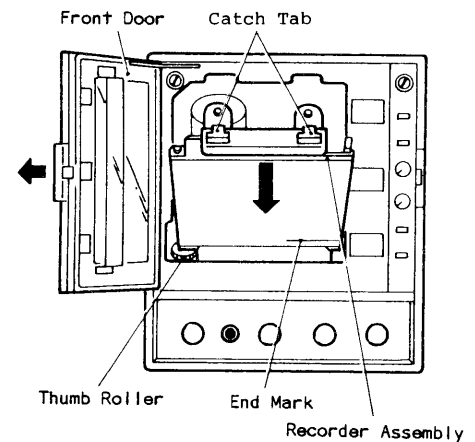

SCALE PLATE CALIBRATIONS

[METERS]

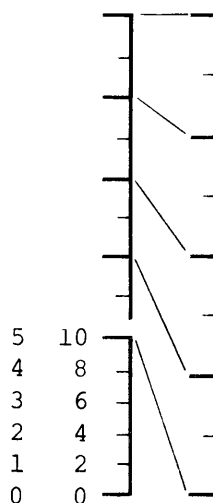

B/L-1 -2

1a	1b	2a	2b	3a	3b	4a	4b	5a	5b	6a	6b
0	10	0	20	0	40	0	100	0	200	0	400
5	15	10	30	20	60	50	150	100	300	200	600
10	20	20	40	40	80	100	200	200	400	400	800
15	25	30	50	60	100	150	250	300	500	600	1000
20	30	40	60	80	120	200	300	400	600	800	1200

[FATHOMS/BRAZAS/PASSIS]

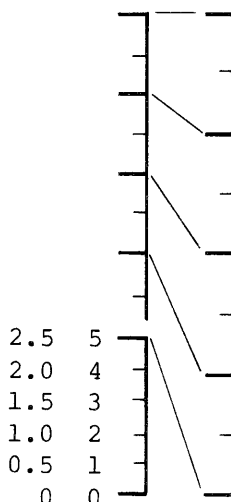

B/L-1 -2

1a	1b	2a	2b	3a	3b	4a	4b	5a	5b	6a	6b
0	5	0	10	0	20	0	50	0	100	0	200
2.5	7.5	5	15	10	30	25	75	50	150	100	300
5	10	10	20	20	40	50	100	100	200	200	400
7.5	12.5	15	25	30	50	75	125	150	250	300	500
10	15	20	30	40	60	100	150	200	300	400	600

[FEET]

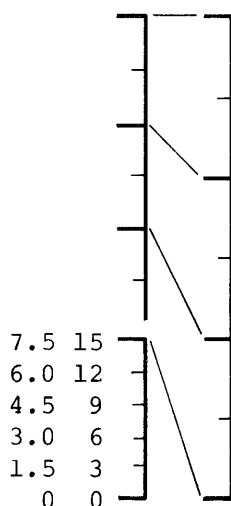

B/L-1 -2

1a	1b	2a	2b	3a	3b	4a	4b	5a	5b	6a	6b
0	15	0	30	0	60	0	150	0	300	0	600
10	25	20	50	40	100	100	250	200	500	400	1000
20	35	40	70	80	140	200	350	400	700	800	1400
30	45	60	90	120	180	300	450	600	900	1200	1800

HOW TO INTERPRET ECHOGRAM

[What is provided on echogram]

Transmission Line

The transmission line is a trace of ultrasonic wave emitted into the water. We often call this line as "Zero Line", however, it indicates not the sea surface but the ship's hull bottom where the transducer is mounted. To know the depth of a target, the ship's draft must be added to the sounding depth. In small boats, this line may be taken as sea surface.

The transmission line can not be seen in a phased range.

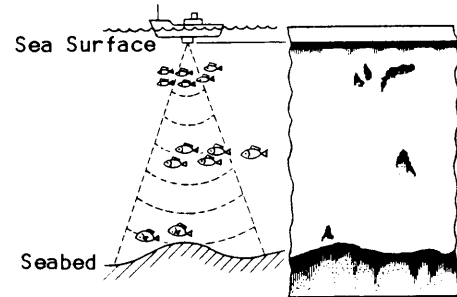

Seabed

The seabed is recorded as comparatively dark trace with some width. Its intensity and width vary with the nature of seabed and characteristics of the echo sounder (frequency, pulse length and receiver characteristics).

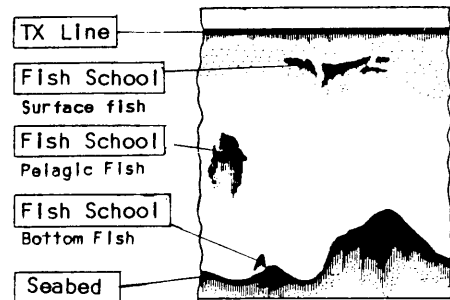

Fish School

The fish school is recorded between the transmission line and seabed (the transmission line is invisible in phased ranges). The shape and size of the fish school trace largely depends on the characteristics of echo sounder and habits of fish species.

In the "bottom-lock" mode, echoes just above the seabed are expanded in the lower part of paper.

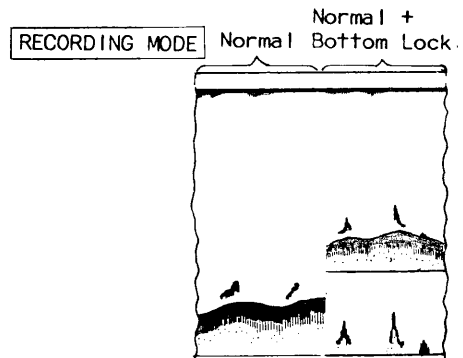

[Variety of echogram with echo sounder characteristics]

Feature of echogram is affected to a great extent by the characteristics of the echo sounder.

Frequency

Characteristics of ultrasonic pulse vary as tabulated below with its frequency, and provides a different type of echogram.

Frequency	Low Frequency	High Frequency
Characteristics, Application		
Beamwidth*	Wide**	Narrow
Sounding Depth	Deep	Shallow
Resolution***	Poor	Good
Affection of Air Bubbles and Water Noise	Large	Little
Suitable Application	<ul style="list-style-type: none"> •Wide area searching •Bottom discrimination 	<ul style="list-style-type: none"> •Identification of fish school density •Discrimination of bottom fish

*Sound pressure of ultrasonic wave is strongest at the center of the beam and goes weaker gradually in the outer part. The beamwidth is the angle of conical beam measured at half pressure points of ultrasonic wave. (Echoes outside the beam can also be recorded if the reflection is strong)

**The beamwidth is, strictly speaking, determined by the size of transducer face. Even in low frequency, it becomes narrower if two or more transducers are placed side by side.

***Ability to distinguish two fish schools closely located at the same depth.

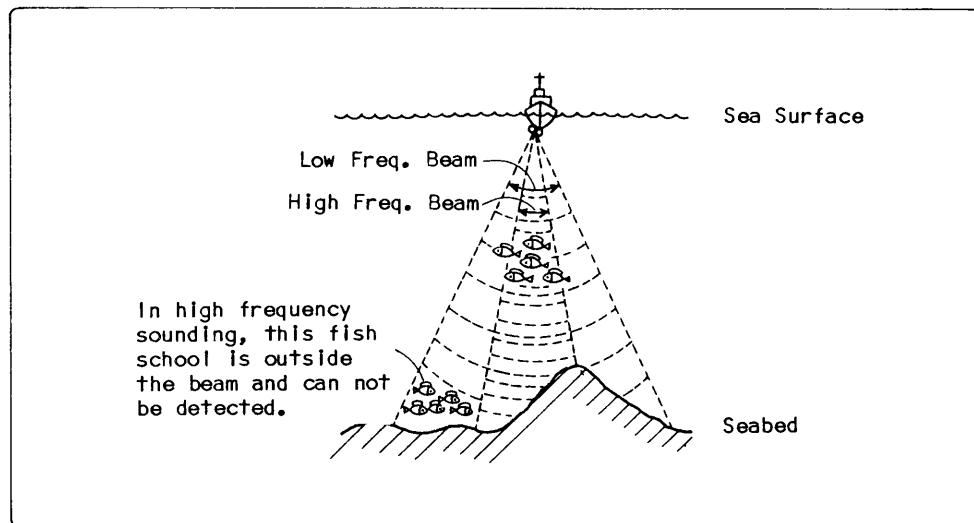

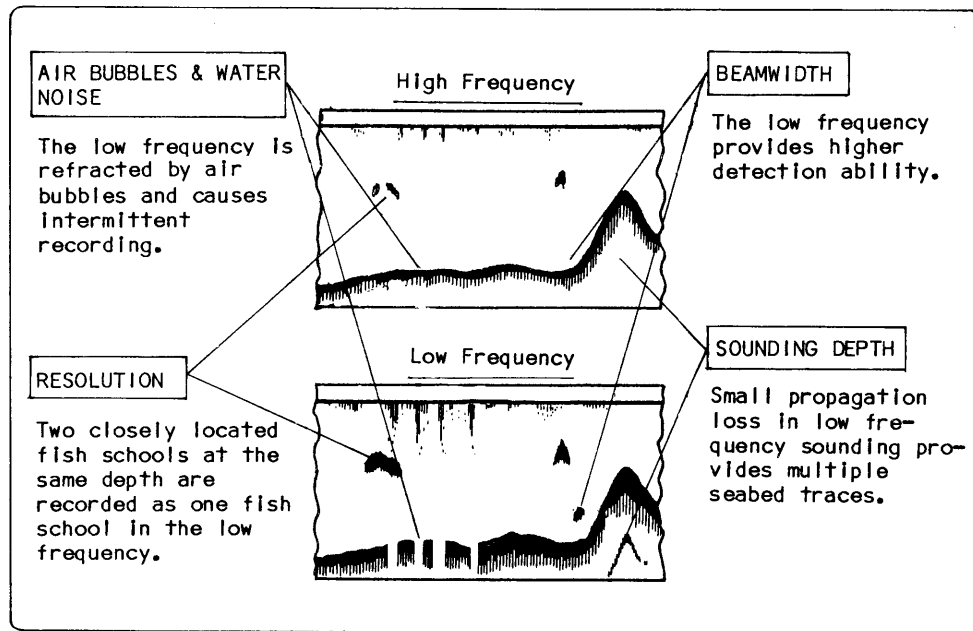

Pulselength

Characteristics of echogram change with pulselength as follows.

Pulselength	Short	Long
Feature, Application		
Range Resolution*	Good	Poor
Sounding Ability**	Poor	Good
Suitable Application	<ul style="list-style-type: none"> • Discrimination of fish distribution • Identification of bottom fish 	<ul style="list-style-type: none"> • Deep sounding • Detection of small fish school

*Ability to distinguish two fish schools closely located at different depths.

**Sounding depth and ability to detect small target.

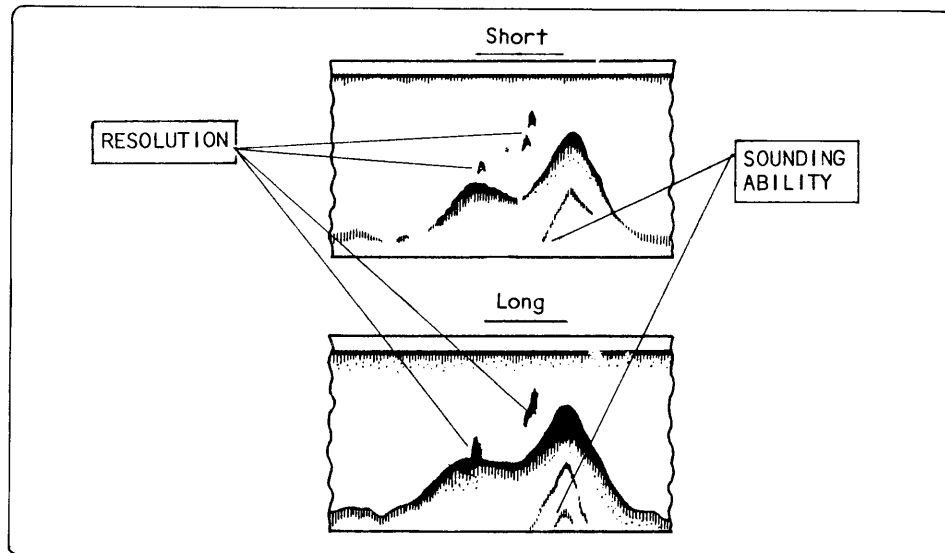

Sounding Rate and Paper Speed

Paper speed and sounding rate are closely related to the density of recordings. The slower paper speed and higher sounding rate make the recording higher in density.

Since characteristics of fish school trace or seabed trace on the echogram change with paper speed and ship's speed as shown below, they should be taken into account for interpretation of the echogram.

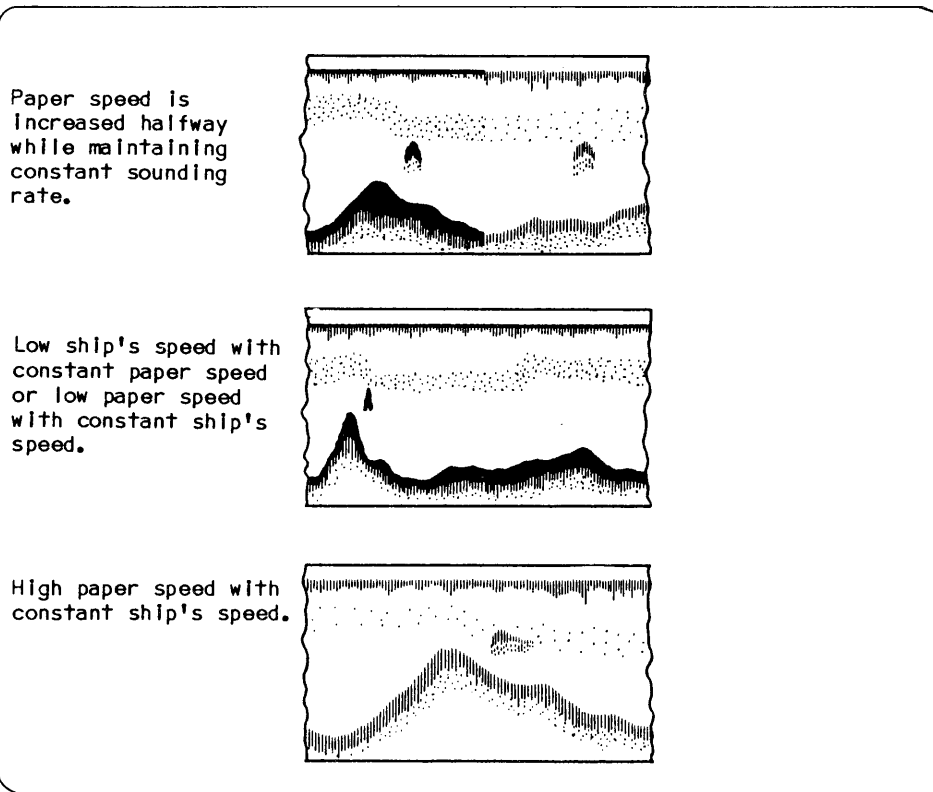

[To read more from echogram]

Fish quantity/Fish School Density

Quantity of fish can be estimated to a certain extent from the trace of fish school. Estimation is based on the following two factors.

* Size of fish school trace

Since size of fish school trace is proportional to the size of actual fish school, it can be used as a basis. However, it should be taken into account that if two traces appear at different depths with the same size, the fish school at shallower depth is actually bigger than that at deeper depth.

The sounding beam of an echo sounder is conical. This indicates that a fish school in a deeper water is hit by the beam for an extended period of time and leaves a wider trace, that is, the trace becomes bigger than the actual size of fish school.

* Intensity of fish trace

Intensity of echo trace is the other basis to estimate fish quantity. In two fish schools of the same size, densely concentrated fish school returns stronger echoes and provides darker trace. However, it should also be kept in mind that if two traces are recorded at different depths with the same intensity, the fish school at deeper place is more densely concentrated.

Since the ultrasonic wave attenuates as it propagates, the trace of a fish school in a deep place becomes weaker than that in shallow place even if they reflect the same amount of wave.

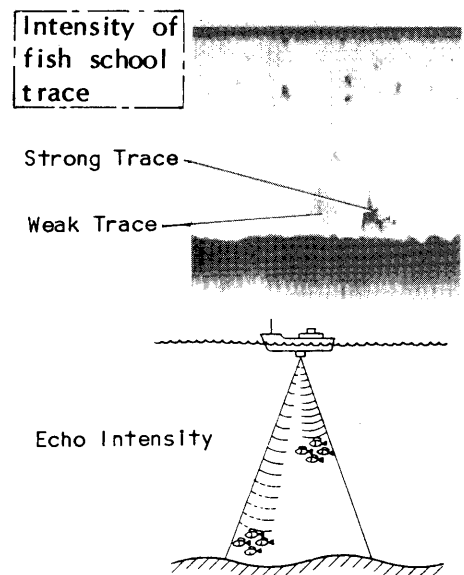
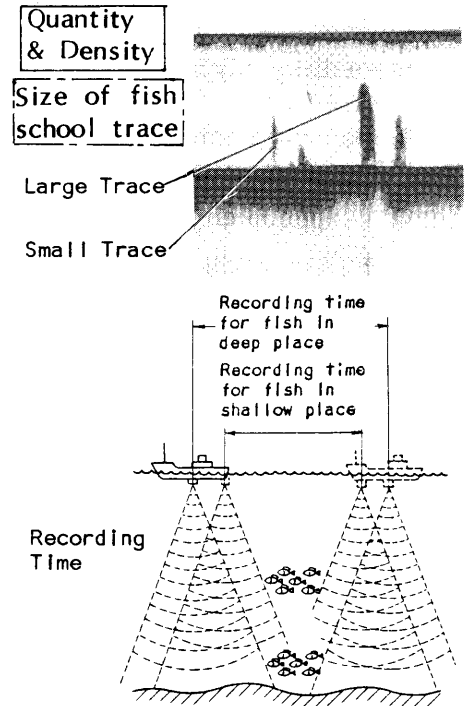

Plankton Layer (DSL)

Cloud-like layer is sometimes registered between the transmission line and seabed. This is a mass of micro organism called plankton. Since fish gather to feed on it as bait, fishing operation of some species of fish is conducted by just observing this trace rather than the trace of aiming fish. Usually the plankton layer lies in deep water by day and rises to shallow water at night.

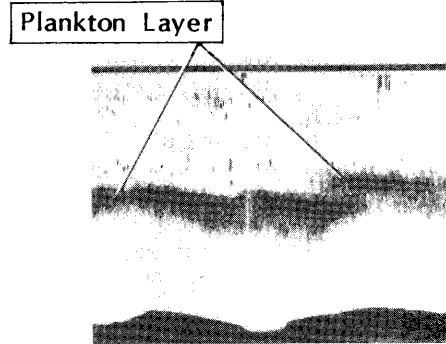

Current Rip

Trace which can be mistaken apparently as noise is plotted in the place called current rip, where two ocean currents meet with different speeds, direction and water temperatures each other. This noise-like trace is either air bubbles or plankton layer. Since fish gather there in search for bait, discrimination of current rip is an important means for finding out a fish school.

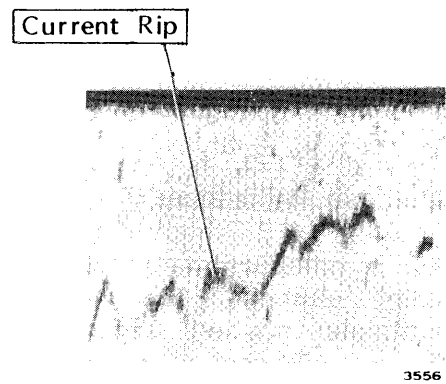

Seabed Condition

It is well known that abundant information useful for fishing is obtained from seabed trace on the echogram. For example, rock piles and wrecks are the places where fish gather.

Seabed Condition

Profile

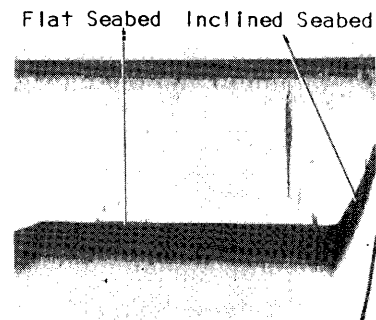

(Seabed Profile)

- * Flat seabed with uniform nature --- Recorded as a trace of constant width.
- * Inclined seabed/Slope of rock piles --- Recorded as a trace with long trail because ultrasonic wave is reflected in different depths.

Note: The tail becomes longer but since the seabed is inclined, apparent width of the seabed trace is narrower.

- * Rough Seabed --- Since echo returns from various directions, they overlap each other and leaves perspective trace.

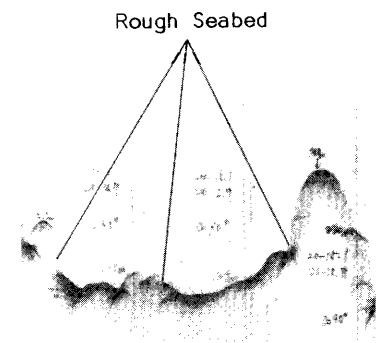

(Nature of Seabed)

- * Hard } Dense trace with long trail
- * Craggy } Dense trace with long trail
- * Mud, sand, alga — Faint trace with short trail

* Bottom of sediment may give a long tail if a low sounding frequency is used.

For bottom discrimination, wide beamwidth (low frequency) and long pulselength are suitable. Further, since the discrimination is done by relative comparison of traces, the gain setting should be kept unchanged.

Nature

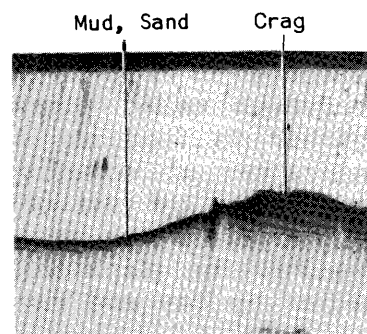

R-212

Multiple Reflection

In a comparatively shallow water with hard seabed, the second or further multiple seabed traces are recorded. These are caused by multiple reflections of the sounding pulses at the seabed and sea surface; the echoes coming back from the seabed are reflected by the sea surface and go down again to the seabed and then return.

The true depth of water is the interval from zero line to the first seabed trace.

The multiple reflection is useable for rough check of transmission power and amplifier sensitivity.

Multiple Reflection

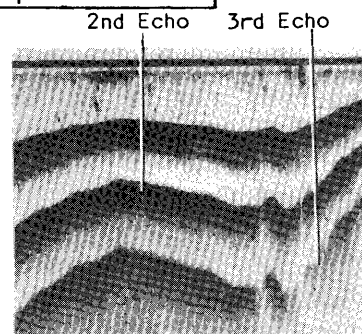

1219

Sea Surface Noise

Sea surface noise is plotted near the transmission line when the sea is rough or when crossing over the wake. The cause of noise is mainly air bubbles.

Proper setting of the TVG control serves to minimize the sea surface noise, allowing distinct echogram.

Sea Surface Noise

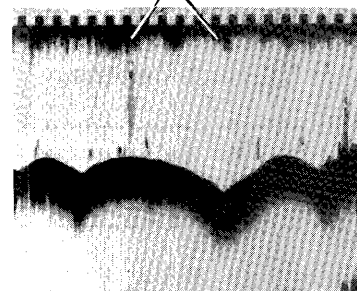

R-283

Interruption of Recording by Air Bubbles

In a rough sea, there is a case that the echogram is occasionally interrupted due to thick air bubbles just below the transducer, blocking the sounding path. This blanks out the recording except the zero line. It also occurs by the wake when the ship makes quick turn or backward movement.

It is quite difficult to eliminate the interruption, especially in low sounding frequency. Reconsideration on installation site of the transducer is needed if the interruption occurs frequently.

Interruption of Recording by Air Bubbles

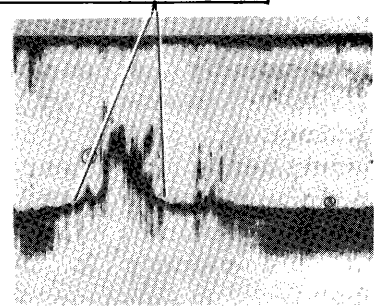

R-184

Zig-zag Seabed Trace

The seabed is recorded zig-zag like the teeth of a saw in a rough sea. This is caused by rolling or pitching of the ship, thereby the sounding direction fluctuates and distance to the seabed varies.

Zig-zagged Bottom Trace

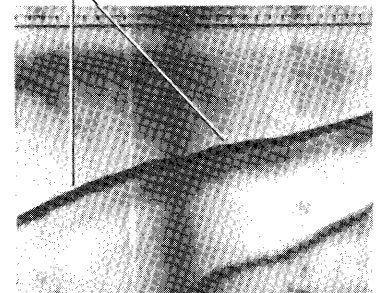

R-61

False Seabed Trace

In the seabed with sharp gradient or high unduration, blurred trace will sometimes appear above the seabed contour, while in flat seabed, it is recorded below the contour. They are false echoes caused by side-lobe of ultrasonic beam.

So far, it is explained that ultrasonic wave is radiated only in the vertical direction as a beam (main-lobe), but in practice, there are some beams outside the main beam that are called "side-lobe". Energy of the side-lobe is fairly weak but it still can provide trace if the reflection is strong.

False Seabed Trace

Undulated Seabed

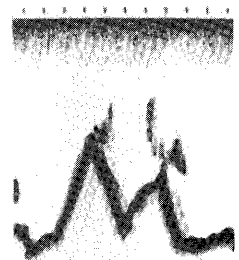

Flat Seabed

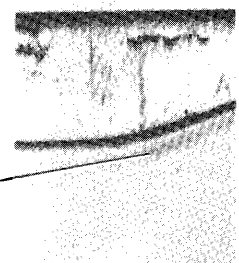

Side-lobe

1944

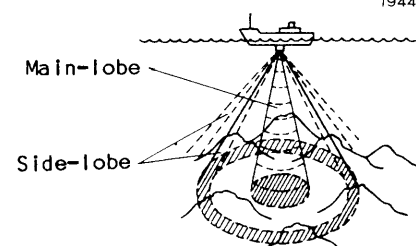

Interference/Noise

There is a case where the echogram is disturbed by interference which appears occasionally or periodically. This is usually caused by such noises as induction from other electronic equipments on board, engine noise, ship's vibrations and interference from an echo sounder of other boats operating in the vicinity in the same frequency band.

The built in Noise Limiter cancels out the random noise by comparing the echoes of last and present soundings.

Interference/ Noise

Interference
from motor,
generator, etc.

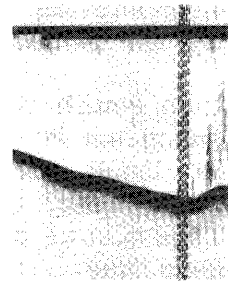

Interference
from other echo
sounder on own
ship.

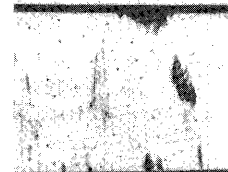

Interference
from echo sounder
on other boat

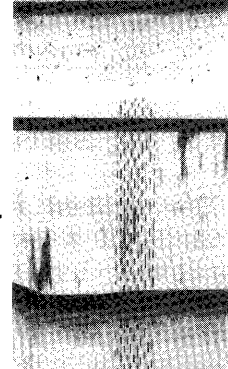

MAINTENANCE

* * * * *

1. Stylus Replacement and Adjustment

Poor or intermittent recording is caused mainly by wear of the stylus nib or collector brush. Check their condition from time to time, and readjust or replace them if necessary.

1. Turn the FUNCTION switch to "O" (off) position.
2. Open the front door, and two fixing screws are in sight. Unfasten the screws and swing down the recorder mechanism.
3. If only the stylus nib is worn, pull it out from the sleeve, using a pair of tweezers or long-nosed pliers, until it is approximately 8mm long.

Too long a nib may cause erratic recordings due to bouncing on the paper.

4. If the collector brush is worn, remove the whole stylus assembly from the recording belt by pressing the holding tang (see drawing), and replace it with new one.
5. Close the recorder mechanism as it was.
6. To smooth the end of the stylus nib, place a scrap of sandpaper (supplied) over the recording paper and turn the power on for several belt revolutions, being careful to keep your fingers away from the moving stylus.
7. If necessary, readjust the setting position of the scale plate to place its zero point at the transmission line. (Make sure that the Draft control is turned fully counter-clockwise!)

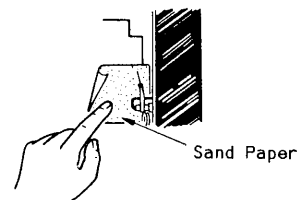
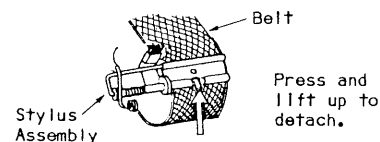
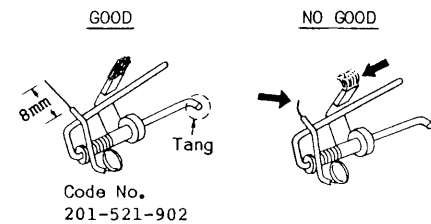
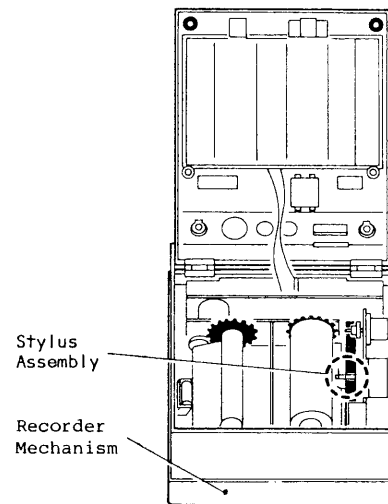
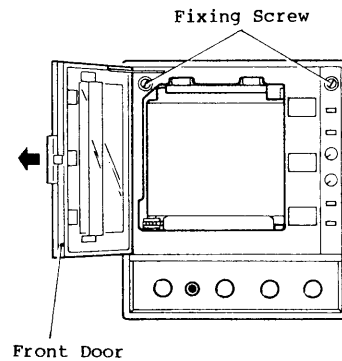

2. Fuse Replacement

A 7A fuse is provided inside the recorder. It may be blown by improper mains voltage/polarity, mechanical overloading or by accidental shortcircuit. If it is blown, first find out the cause of the trouble, and then replace the fuse. Never use a larger fuse to avoid serious damage to the circuitry. When replacing the fuse, turn off the ship's mains switch to avoid accidental shortcircuiting.

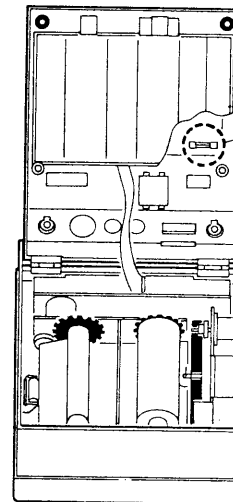

7A Fuse
Code No.
000-547-011

3. Cleaning

Keep recorder clean using a clean moistened cloth rag. Put vinyl cover on when it is not used.



Do not use plastic solvent or active chemicals for cleaning.

Dry recording paper inherently creates powder dust. Clean the recorder interior using the brush supplied inside the cabinet.

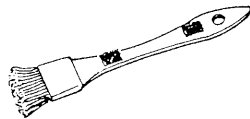

Keep transducer face clean.

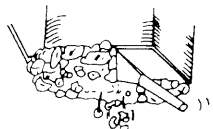
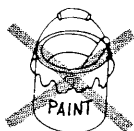

Oysters or seaweed on the transducer face will result in degraded detecting performance. Gently remove them when dry-docked. Do not paint on the face.

Keep good contact at all the terminals.

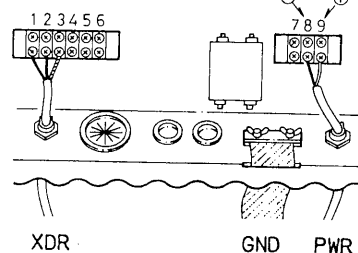

TROUBLESHOOTING

* * * * *

The following table shows simple troubleshooting that can be done by the operator himself. Problems not covered here are best referred to a qualified electronics technicians.

Symptom	Possible Cause	Remedy
Not working at all	<ol style="list-style-type: none"> 1. Switch at main switch board is turned off. 2. Power connection is loose or out. 3. Too low input voltage (Battery is flat.) 4. Fuse on main board is blown. 	<ol style="list-style-type: none"> 1. Turn on the main switch. 2. Secure connection firmly. 3. Check mains voltage is within 10.5 to 40VDC. 4. If blown, check mains voltage first, and then replace 7A fuse. See page 3-2.
Lamp/LED lit, but motor is not rotating.	<ol style="list-style-type: none"> 1. Poor connection inside 	<ol style="list-style-type: none"> 1. Check that connectors on the boards are firmly plugged in.
Motor rotating, but no recording	<ol style="list-style-type: none"> 1. Stylus nib or collector brush is worn. 2. Poor connection inside 3. DRAFT control is set too deep while using shallow ranges. 	<ol style="list-style-type: none"> 1. Readjust or replace it. See page 3-1. 2. Check that connectors on the boards are firmly plugged in. 3. Readjust DRAFT control.
Zero line but no echo trace	<ol style="list-style-type: none"> 1. GAIN control is set too low. 2. Transducer connection is loose or out. 3. Transducer is not in contact with water. 	<ol style="list-style-type: none"> 1. Increase the GAIN. 2. Secure connection firmly. 3. Put transducer in water.
Recording is faint and dim.	<ol style="list-style-type: none"> 1. Stylus nib is formed improperly. 2. Thick dirt on front window 	<ol style="list-style-type: none"> 1. Readjust stylus nib. See page 3-1. 2. Clean up window.
Recording is too dark and heavy.	<ol style="list-style-type: none"> 1. Gain is set too high. 2. Stylus is bent to tear paper. 	<ol style="list-style-type: none"> 1. Decrease the GAIN. 2. Readjust stylus nib.
Uneven intensity in recording	<ol style="list-style-type: none"> 1. Stain on collector rail. 	<ol style="list-style-type: none"> 1. Polish up rail.

Symptom	Possible Cause	Remedy
Irregular paper advance	<ol style="list-style-type: none"> 1. Recorder assembly is not fully snapped in. (Pinch roller not engaged) 2. Reduction gear of take-up motor jammed. 	<ol style="list-style-type: none"> 1. Push in the recorder assembly. 2. Remove paper dust on the gears.
Chart recording OK but digital display abnormal (unreadable)	<ol style="list-style-type: none"> 1. Loose connection inside 	<ol style="list-style-type: none"> 1. Check plug connections on the boards.
Seabed depth reading is incorrect or unstable.	<ol style="list-style-type: none"> 1. SHADOW LINE control is not adjusted for seabed. 2. Strong interference or dense fish school exist. 3. Seabed is out of recording range. 	<ol style="list-style-type: none"> 1,2. Readjust GAIN and/or SHADOW LINE control. 3. Select a depth range to see seabed echo.

SPECIFICATIONS OF FE-808 ECHO SOUNDER
 * * * * *

1. DEPTH RANGE, SOUNDING RATE & PULSELENGTH:

RANGE		FE-808M (meter)	FE-808FT (foot)	FE-808FA/PA (fathom,passi)	SOUNDING RATE(/min.)	PULSELENGTH (msec)			
N O R M A L	1	a	0- 20	0- 30	0- 10	376	0.4		
		b	10- 30	15- 45	5- 15				
	2	a	0- 40	0- 60	0- 20				
		b	20- 60	30- 90	10- 30				
	3	a	0- 80	0- 120	0- 40			188	1.0
		b	40- 120	60- 180	20- 60				
	4	a	0- 200	0- 300	0-100	94			
		b	100- 300	150- 450	50-150				
	5	a	0- 400	0- 600	0-200	47	2.0		
		b	200- 600	300- 900	100-300				
	6	a	0- 800	0-1200	0-400	23.5(*)			
		b	400-1200	600-1800	200-600				
BOTTOM LOCK	1	5	7.5	2.5	*: 47 for foot scale				
	2	10	15	5					

- 2. RECORDING SYSTEM: Straight line recording
- 3. PRESENTATION MODE: a) Normal(full paper width)
b) Normal(upper 2/3) plus Bottom Lock(lower 1/3)
- 4. RECORDING PAPER: Dry electrosensitive paper
Type; PD-2020NW (204mmx20m)
- 5. PAPER SPEED: Range 1-3: 6, 9 or 18mm/min.
Range 4-6: 2, 3 or 6mm/min.
- 6. INTENSITY GRADATION: Light-gray, gray and black
- 7. FREQUENCY & TRANSDUCER: 28kHz : 28F-8(Std.), 28F-18(Opt.)
50kHz : 50B-6(Std.), 50B-9(Opt.), 50F-8G(Opt.)
60kHz : 60B-5S(Std.), 60B-52(Opt.)
88kHz : 88B-8(Std.), 88B-10(Opt.)
200kHz: 200B-5S(Std.), 200B-8/8N(Opt.)
- 8. OUTPUT POWER: 500W nominal
- 9. CONTROLS / SWITCHES: Front Panel: a) Range b) Gain
c) Shadow Line
d) Function (OFF/ON/BL-1/2)
e) Event Marker
Sub-Panel: a) Noise Limiter
b) Paper Speed
c) TVG (Time Varied Gain)
d) Draft (zero line shift)
e) Power Reduction
f) Lamp
- 10. DIGITAL READOUT: a) Start depth and end depth
[Shadow Line OFF]
b) Start depth, seabed depth and end depth
[Shadow Line ON]
- 11. POWER SUPPLY: 10.5 to 40VDC universal, 50W approx.
- 12. DIMENSIONS & WEIGHT: 366(W) x 418(H) x 138(D)mm, 12.2kg

[EQUIPMENT LIST]

No.	Name	Type	Q'ty	Remarks
1	Recorder Unit	FE-808	1	
2	Transducer		1	
3	Installation Materials		1 set	See separate list.
4	Spare Parts		1 set	See separate list.
5	Vinyl Cover	02-038-0001	1	Code No.: 000-879-498

[STANDARD SPARE PARTS]

No.	Name	Type	Code No.	Q'ty	Remarks
1	Fuse	F-7161, 7A	000-547-011	1	
2	Recording Stylus	02-015-2190-2	201-521-902	1	
3	Sand Paper	#240 90x90mm	000-835-008	1	
4	Recording Paper	PD-2020NW	000-878-457	1	
5	Pilot Lamp	P-12, 50mA	000-540-156	2	w/WHT leads

[INSTALLATION MATERIALS]

No.	Name	Type	Code No.	Q'ty	Remarks
1	Vinyl Cable	VCTF1.25x2C,5m	000-564-502	1	for power
2	Crimp-on Lug	FV1.25-3 RED	000-538-113	5	

[TRANSDUCER/TANK/THRU-HULL PIPE]

FREQUENCY	TRANSDUCER	TANK	THRU-HULL PIPE	USE
28kHz	28F-8 (000-015-003) Standard	T-604 (000-015-512)	TFB-5000 (000-015-206)	Steel Hull
		T-604-W (000-015-514)	TFB-1000 (000-015-201)	Wooden Hull
		T-604-F (000-015-513)	TRB-1000 (000-015-215)	Plastic Hull
		T-514 (000-015-416)	_____	Sideboard
	28F-18 (000-015-004) Option	T-612 (000-015-534)	TFB-5000 (000-015-206)	Steel Hull
		T-612-W (000-015-536)	TFB-1000 (000-015-201)	Wooden Hull
		T-612-F (000-015-535)	TRB-1000 (000-015-215)	Plastic Hull
		T-2 (000-015-302)	_____	Sideboard
50kHz	50B-6 (000-015-042) Standard	T-605 (000-015-515)	TFB-5000 (000-015-206)	Steel Hull
		T-605-W (000-015-517)	TFB-1000 (000-015-201)	Wooden Hull
		T-605-F (000-015-516)	TRB-1000 (000-015-215)	Plastic Hull
		T-27 (000-015-313)	_____	Sideboard
	50B-9 (000-015-064) Option	T-603 (000-015-509)	TFB-5000 (000-015-206)	Steel Hull
		T-603-W (000-015-511)	TFB-1000 (000-015-201)	Wooden Hull
		T-603-F (000-015-510)	TRB-1000 (000-015-215)	Plastic Hull
		T-63 (000-015-326)	_____	Sideboard

FREQUENCY	TRANSDUCER	TANK	THRU-HULL PIPE	USE
50kHz	50F-8G (000-015-066) Option	T-612 (000-015-534)	TFB-5000 (000-015-206)	Steel Hull
		T-612-W (000-015-536)	TFB-1000 (000-015-201)	Wooden Hull
		T-612-F (000-015-535)	TRB-1000 (000-015-215)	Plastic Hull
		T-2 (000-015-302)	—————	Sideboard
60kHz	60B-5S (000-015-021) Standard	T-605 (000-015-515)	TFB-5000 (000-015-206)	Steel Hull
		T-605-W (000-015-517)	TFB-1000 (000-015-201)	Wooden Hull
		T-605-F (000-015-516)	TRB-1000 (000-015-215)	Plastic Hull
		T-27 (000-015-313)	—————	Sideboard
	60B-52 (000-015-022) Option	T-603 (000-015-509)	TFB-5000 (000-015-206)	Steel Hull
		T-603-W (000-015-511)	TFB-1000 (000-015-201)	Wooden Hull
		T-603-F (000-015-510)	TRB-1000 (000-015-215)	Plastic Hull
		T-63 (000-015-326)	—————	Sideboard
88kHz	88B-8 (000-015-024) Standard	T-606 (000-015-518)	TFB-5000 (000-015-206)	Steel Hull
		T-606-W (000-015-520)	TFB-1000 (000-015-201)	Wooden Hull
		T-606-F (000-015-519)	TRB-1000 (000-015-215)	Plastic Hull
		T-221 (000-015-366)	—————	Sideboard
	88B-10 (000-015-025) Option	T-609 (000-015-528)	TFB-5000 (000-015-206)	Steel Hull
		T-609-W (000-015-530)	TFB-1000 (000-015-201)	Wooden Hull
		T-609-F (000-015-529)	TRB-1000 (000-015-215)	Plastic Hull
		T-501 (000-015-401)	—————	Sideboard
200kHz	200B-5S (000-015-029) Standard	T-605 (000-015-515)	TFB-5000 (000-015-206)	Steel Hull
		T-605-W (000-015-517)	TFB-1000 (000-015-201)	Wooden Hull
		T-605-F (000-015-516)	TRB-1000 (000-015-215)	Plastic Hull
		T-27 (000-015-313)	—————	Sideboard
	200B-8 (000-015-030) 200B-8N (000-015-045) Option	T-608 (000-015-525)	TFB-5000 (000-015-206)	Steel Hull
		T-608-W (000-015-527)	TFB-1000 (000-015-201)	Wooden Hull
		T-608-F (000-015-526)	TRB-1000 (000-015-215)	Plastic Hull
		T-31 (000-015-317)	—————	Sideboard

INSTALLATION

* * * * *

1. Selection of Installation Site

Transducer

The performance of the echo sounder depends greatly upon the transducer position. The following points should be taken into account:

- * Select a place not effected by air bubbles.

It is known that bubbles are at minimum at the place where the first bow wave falls and the next wave rises at general cruising speed. In small boats with slow speed, midship position is usually a good place. In high speed boats, select a place where the transducer is always in contact with the water.

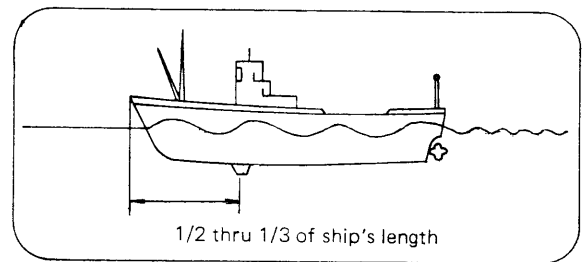

- * If it is possible, put the transducer flush on the keel line.
- * To further reduce the effect of air bubbles, it is recommended to project the transducer by approx. 250mm from the hull plate, but not below the keel level.
- * The transducer must be facing the sea bottom in normal cruising trim of the vessel.
- * Select a place as far from engine, generator, motor or other electric equipments as possible.

A fairing block will be necessary both to prevent turbulence related problems and to protect the transducer from damage due to debris in the water. The fairing block should be fabricated locally by a shipyard skilled in such specialized work.

The transducer can also be installed on the sideboard using pipe and clamps, but note that the boat has to be small in size and slow in speed due to limited strength of the transducer pipe.

Recorder Unit

The recorder unit can be installed in any convenient place in the steering bridge. To expect extended performance, however, the following points should also be taken into consideration:

- * Select a well ventilated place not exposed to direct sunbeam and water splash.
- * Select a place sufficiently far apart from noise generating equipment, radio equipment and antenna feeders.
- * Select a place convenient for operation, observation, maintenance and future service.

2. Mounting

Transducer

Refer to the drawings on pages AP2-4 thru AP2-6 for typical installations.

Recorder Unit

The recorder unit can be mounted on table-top (an optional mounting bracket is required), bulkhead or interior bulkhead.

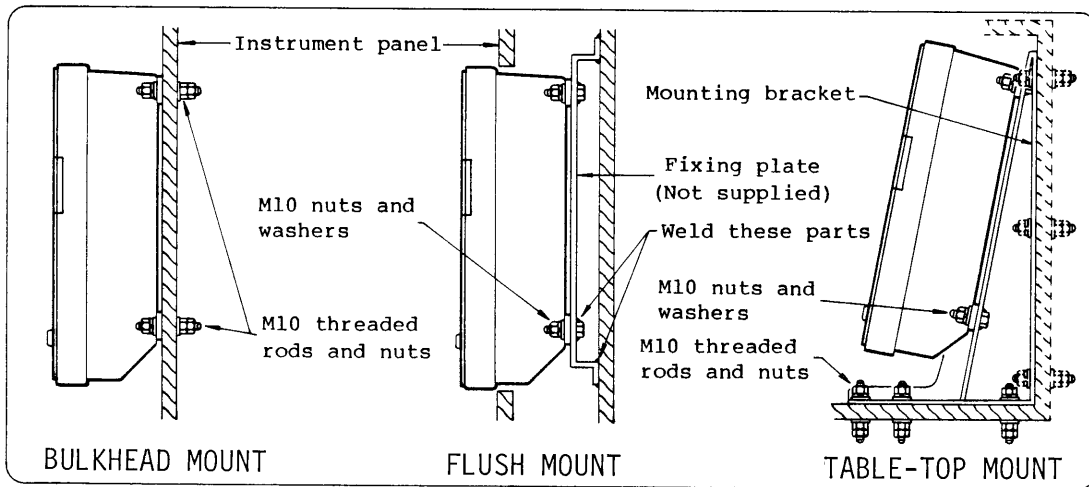

3. Cable Connections

Two cables (power cable and transducer cable) and grounding copper strap are connected to the receiver unit. (Refer to page AP2-7 for connection diagram.)

Power Cable

Fabricate the one end of the power cable with crimp-on lugs supplied as installation materials. The other end of the cable is connected to the battery or the rectifier.

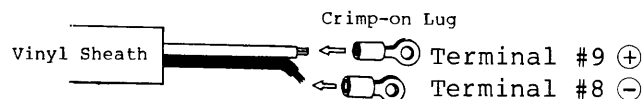

Transducer Cable

Fabricate the one end of the transducer cable with crimp-on lugs supplied as installation materials.

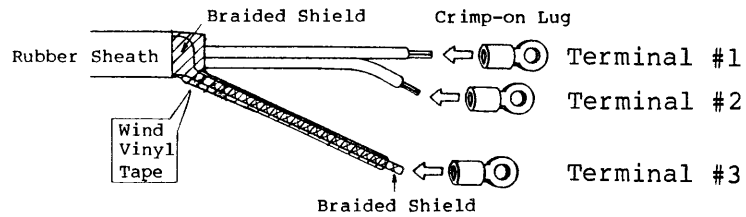

Note 1. Terminals #1 and #2 have no polarity.

Note 2. Don't fail to treat the shield with vinyl tape to prevent shortcircuit.

Ground Copper Strap

Since a sheet of copper strap is not supplied, it should be prepared locally.

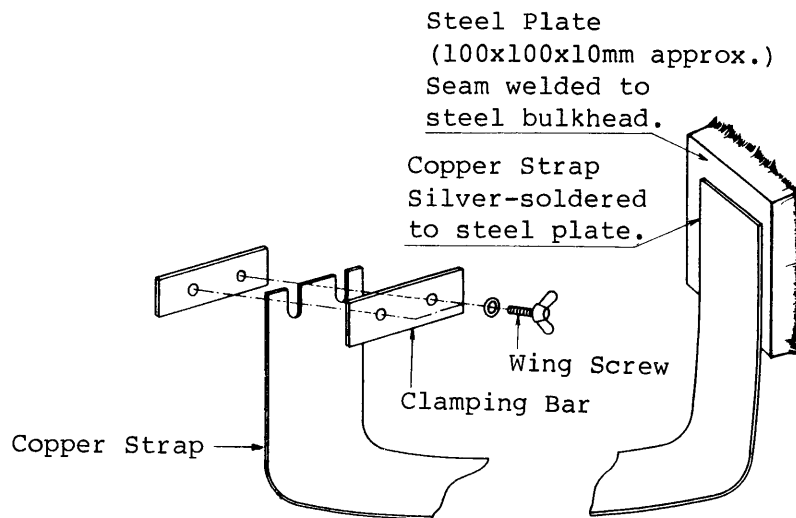

Note 1. The length of copper strap should be limited for good ground effect.

2. For FRP or wooden boat, copper strap should be brazed to nearest earth point.

EXAMPLES OF TRANSDUCER INSTALLATION

[HULL BOTTOM MOUNT]

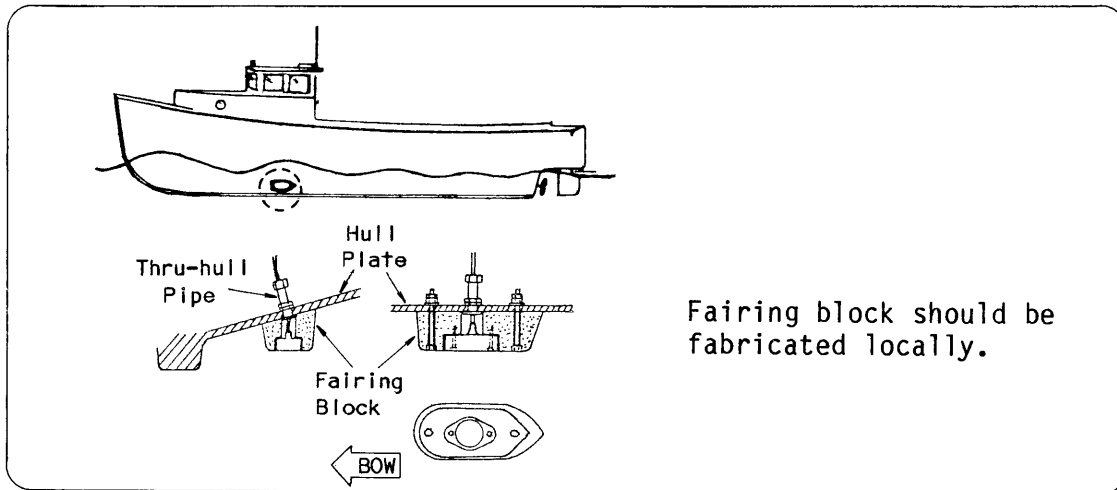

[SIDEBORD MOUNT]

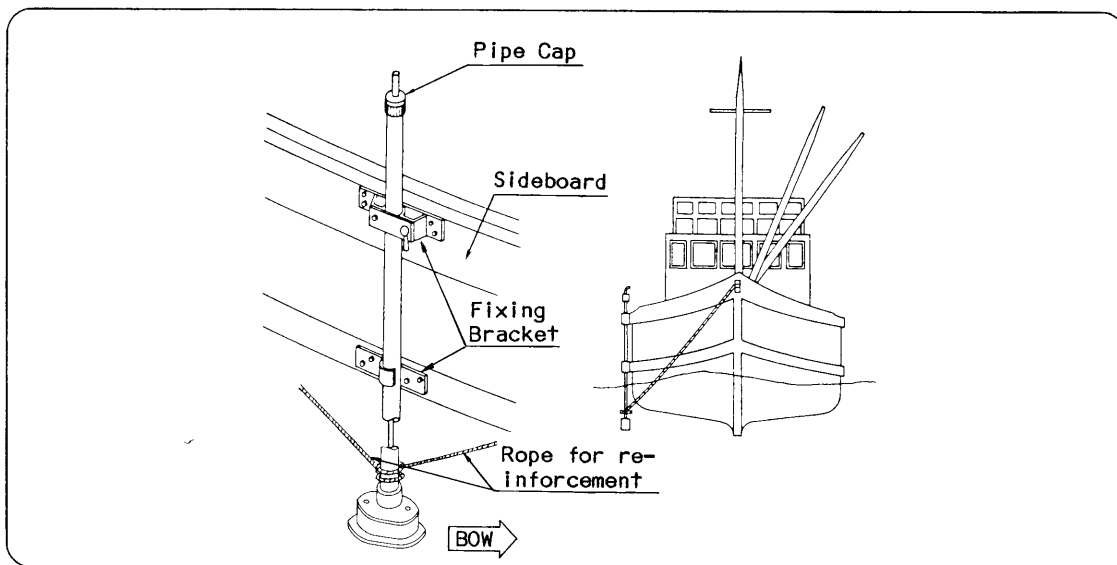

[TRANSOM MOUNT]

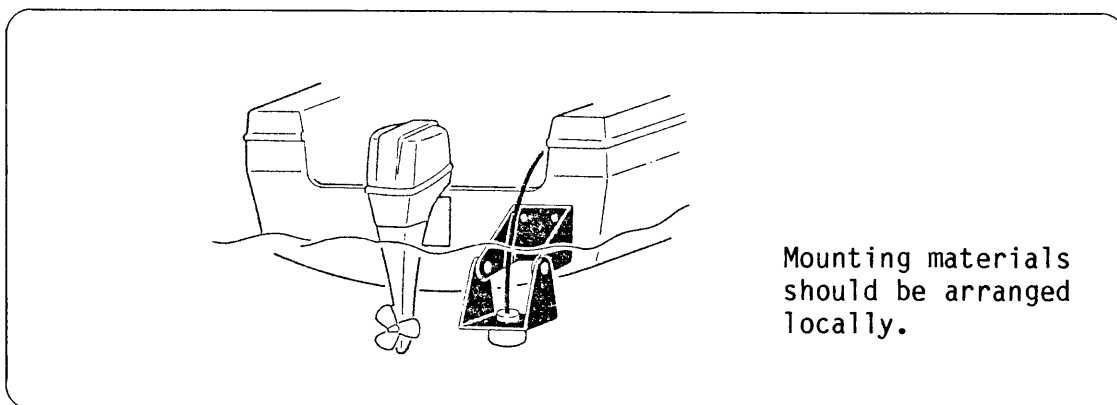

[TRANSDUCER TANK]

STEEL HULL

T-605

TRANSDUCER: 50B-6(6B),
60B-5S,
200B-5S

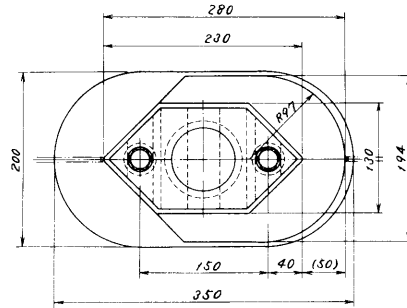
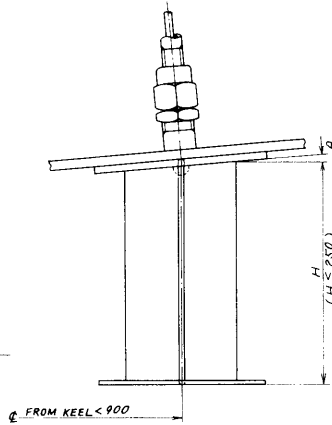
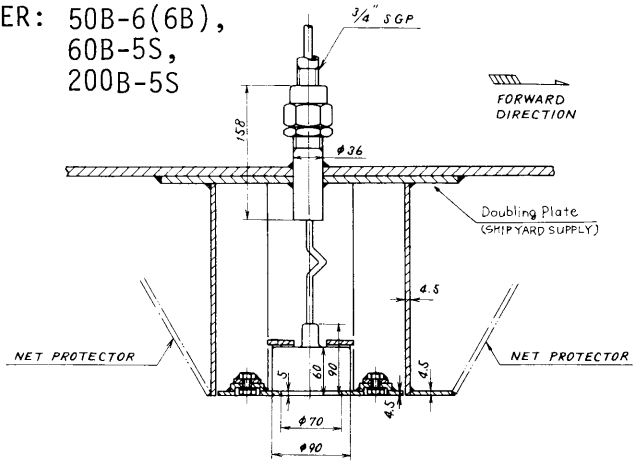

- NOTE: 1. Do not paint transducer face.
2. Do not apply either strong mechanical shock to the transducer or intense stress to the cable.
3. Be careful not to give damage to the transducer and cable while welding.

WOODEN HULL

T-605-W

TRANSDUCER: 50B-6(6B), 60B-5S, 200B-5S

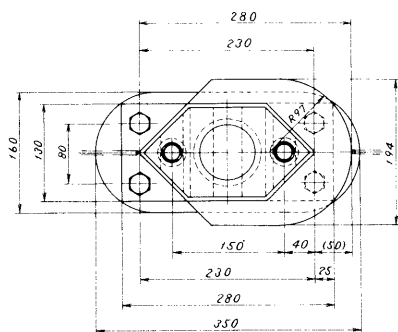
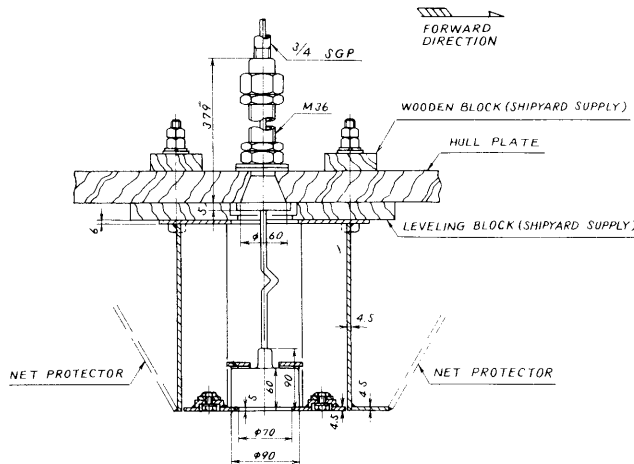

PLASTIC HULL

T-605-F

TRANSDUCER: 50B-6(6B), 60B-5S, 200B-5S

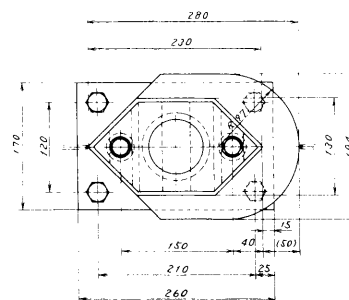
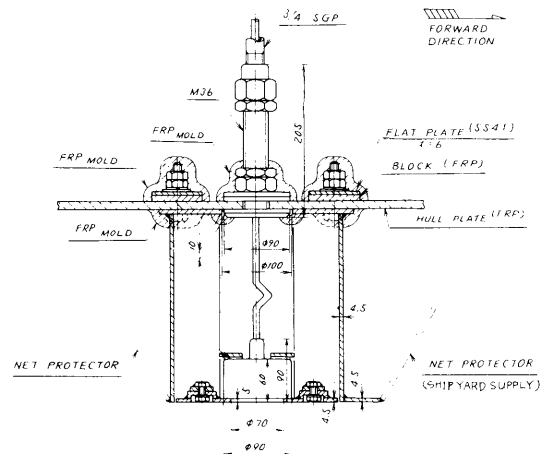

[TRANSDUCER TANK]

STEEL HULL

TRANSDUCER: 88B-8

T-606

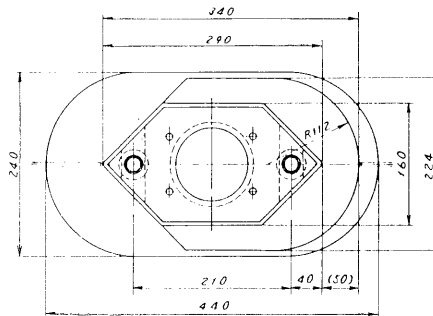
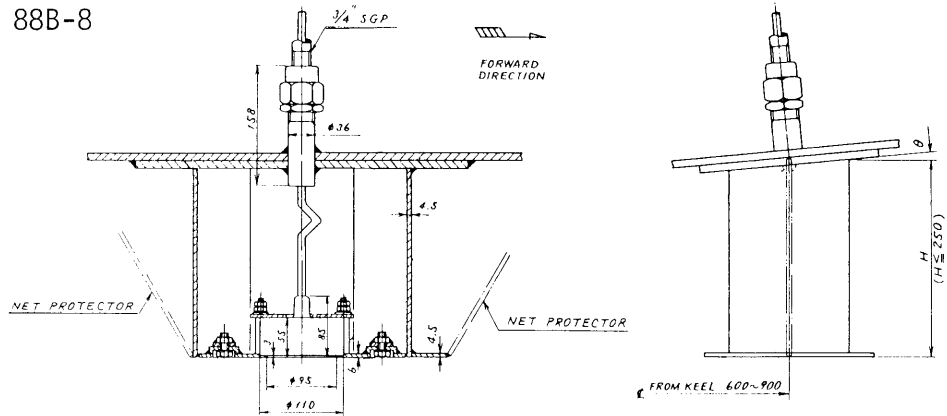

- NOTE: 1. Do not paint transducer face.
 2. Do not apply either strong mechanical shock to the transducer or intense stress to the cable.
 3. Be careful not to give damage to the transducer and cable while welding.

WOODEN HULL

TRANSDUCER: 88B-8

T-606-W

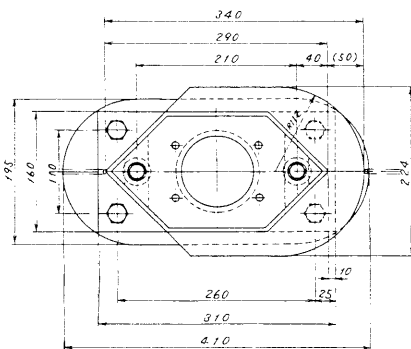
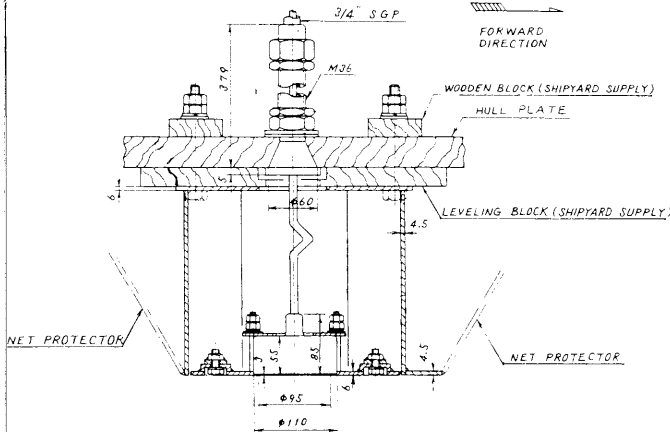

PLASTIC HULL

TRANSDUCER: 88B-8

T-606-F

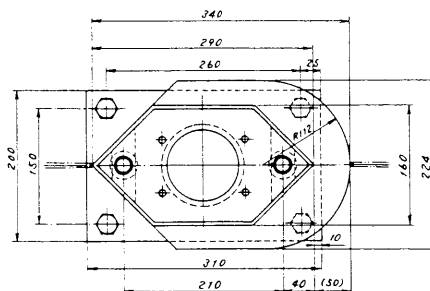
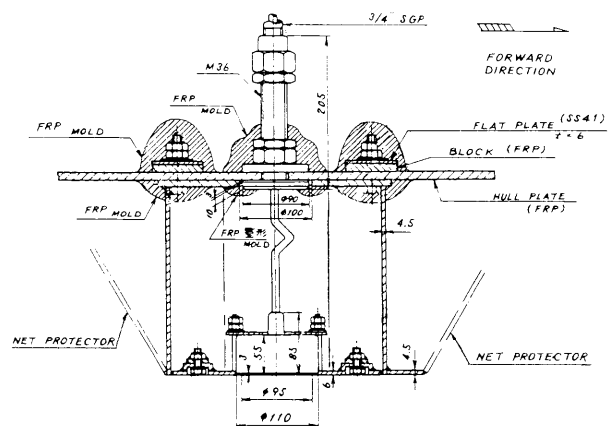

CONNECTION DIAGRAM

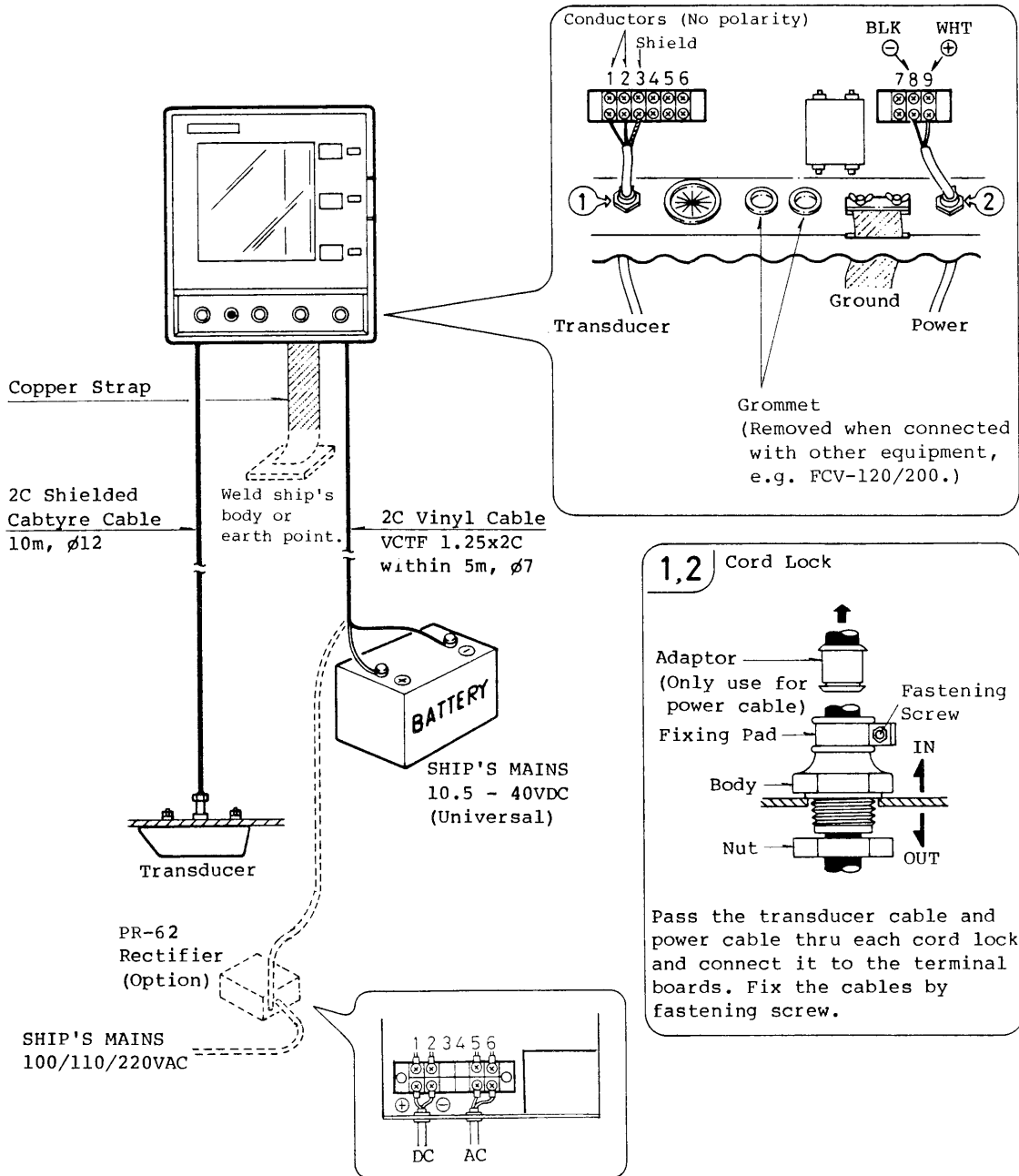

A

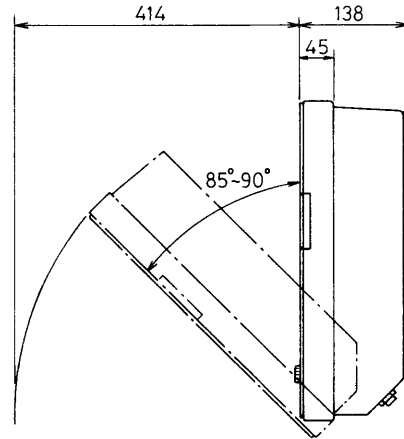
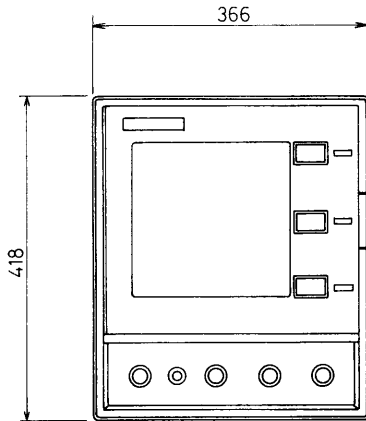

B

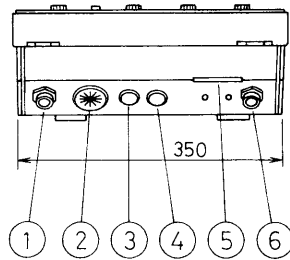

取付寸法
MOUNTING DIMENSION

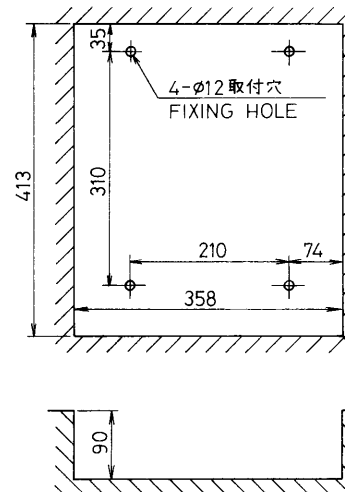

C

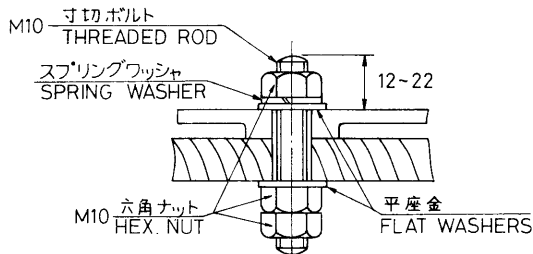

取付例
EXAMPLE OF MOUNTING

D

コンパス安全距離
COMPASS SAFE DISTANCE

スタンダード STANDARD	1.3M
ステアリング STEERING	0.98M

6	電源ケーブル導入口 POWER CABLE ENTRY		1		
5	アース銅板導入口 COPPER STRAP ENTRY		1		
4	予備穴 OPTION CABLE ENTRY		1		
3	予備穴 OPTION CABLE ENTRY		1		
2	排気用穴 EXHAUST		1		
1	送受波器ケーブル導入口 XDR CABLE ENTRY		1		
品番 ITEM	品名 NAME	材質 MATERIAL	数量 Q'TY	図番 DWG.NO.	摘要 REMARKS

承認
APPROVED

NOV 11 '83
[Signature]

三角法
THIRD ANGLE PROJECTION

名称
TITLE
FE-808

RECORDER UNIT
記録器外觀
(BULKHEAD, FLUSH MOUNT TYPE)
(壁掛、埋込型)

検
CHECKED

尺度
SCALE
1 / 10

製
DRAWN

重量
WEIGHT
12.2 kg

図番
DWG.NO.
C2285-006-B

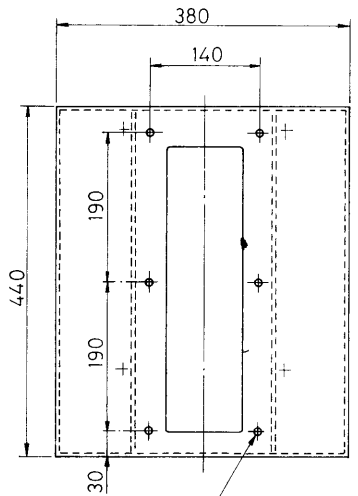
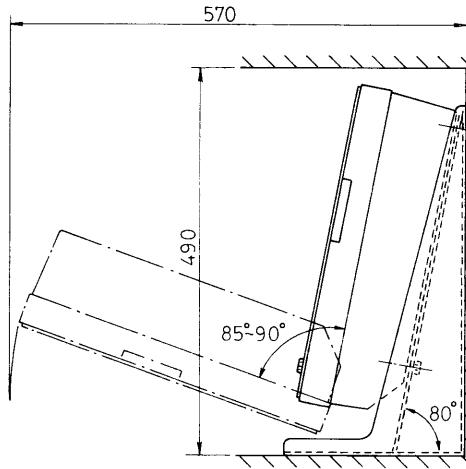
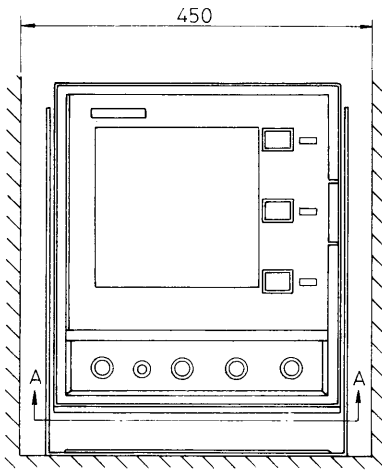

6-φ10 取付穴
FIXING HOLE

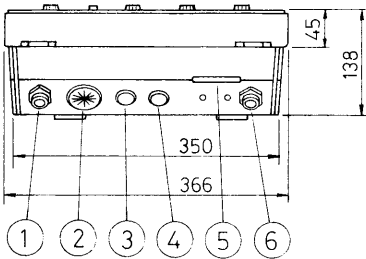

SECTION A-A

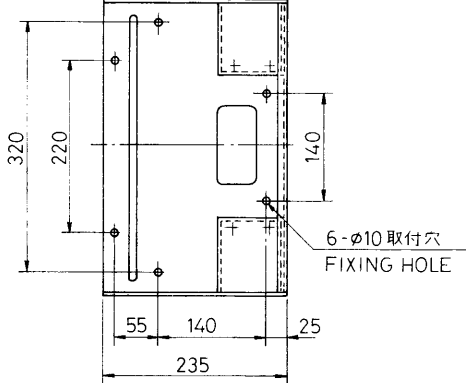

6-φ10 取付穴
FIXING HOLE

NOTE 1. 取付台はオプション
MOUNTING BRACKET IS OPTIONAL SUPPLY

コンパス安全距離
COMPASS SAFE DISTANCE

スタンダード STANDARD	1.3M
ステアリング STEERING	0.98M

6	電源ケーブル導入口 POWER CABLE ENTRY		1		
5	アース銅板導入口 COPPER STRAP ENTRY		1		
4	予備穴 OPTION CABLE ENTRY		1		
3	予備穴 OPTION CABLE ENTRY		1		
2	排気用穴 EXHAUST		1		
1	送受信ケーブル導入口 XDR CABLE ENTRY		1		

品番 ITEM	品名 NAME	材質 MATERIAL	数量 Q'TY	図番 DWG.NO.	摘要 REMARKS
------------	------------	----------------	------------	---------------	---------------

承認 APPROVED	Nov. 11. 1983 <i>[Signature]</i>	三角法 THIRD ANGLE PROJECTION		名称 TITLE	RECORDER UNIT 記録器外觀図
検図 CHECKED		尺度 SCALE	1/10	FE-808	(TABLE-TOP MOUNT TYPE) (卓上型)
製図 DRAWN		重量 WEIGHT	12.2 (本体) 6.5 (取付台) kg (BRACKET)	図番 DWG.NO.	C2285-007-B

HOW TO CHANGE CALIBRATION UNIT

The FE-808 can provide depth readout in one of four units; meters, feet, fathoms or brazas/passis. Note that the equipment is factory-set to "meters" unless noted otherwise.

If necessary, change calibration unit following the procedure below.

[Procedure]

1. Change the positions of two jumper plugs. Open the recorder cabinet, remove the dust cover colored black, and the MAIN p.c. board is in sight. One jumper plug J7 is mounted on the p.c. board. The other jumper plug S1 is located on the DISPLAY p.c. board. S1 is selectable between feet and others. See figure and table below.

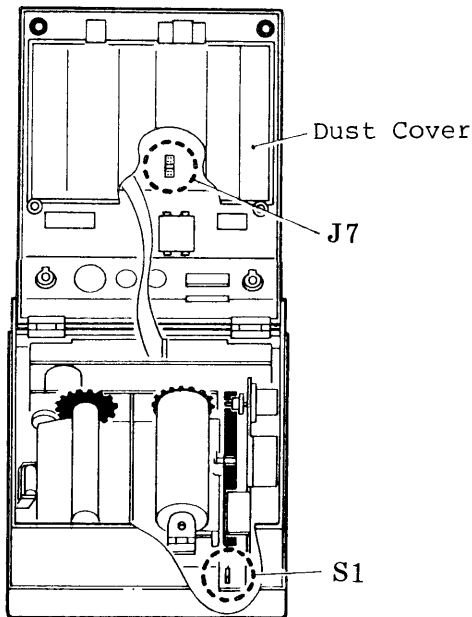

Unit	Jumper Plugs	
	J7	S1
Meters	M	FT OTHERS
Fathoms	FA	FT OTHERS
Brazas/ Passis	P	FT OTHERS
Feet	FT	FT OTHERS

2. When changed to feet, you should also change the scale for feet. The scale is optional supply. (Code No. 203-813-130)

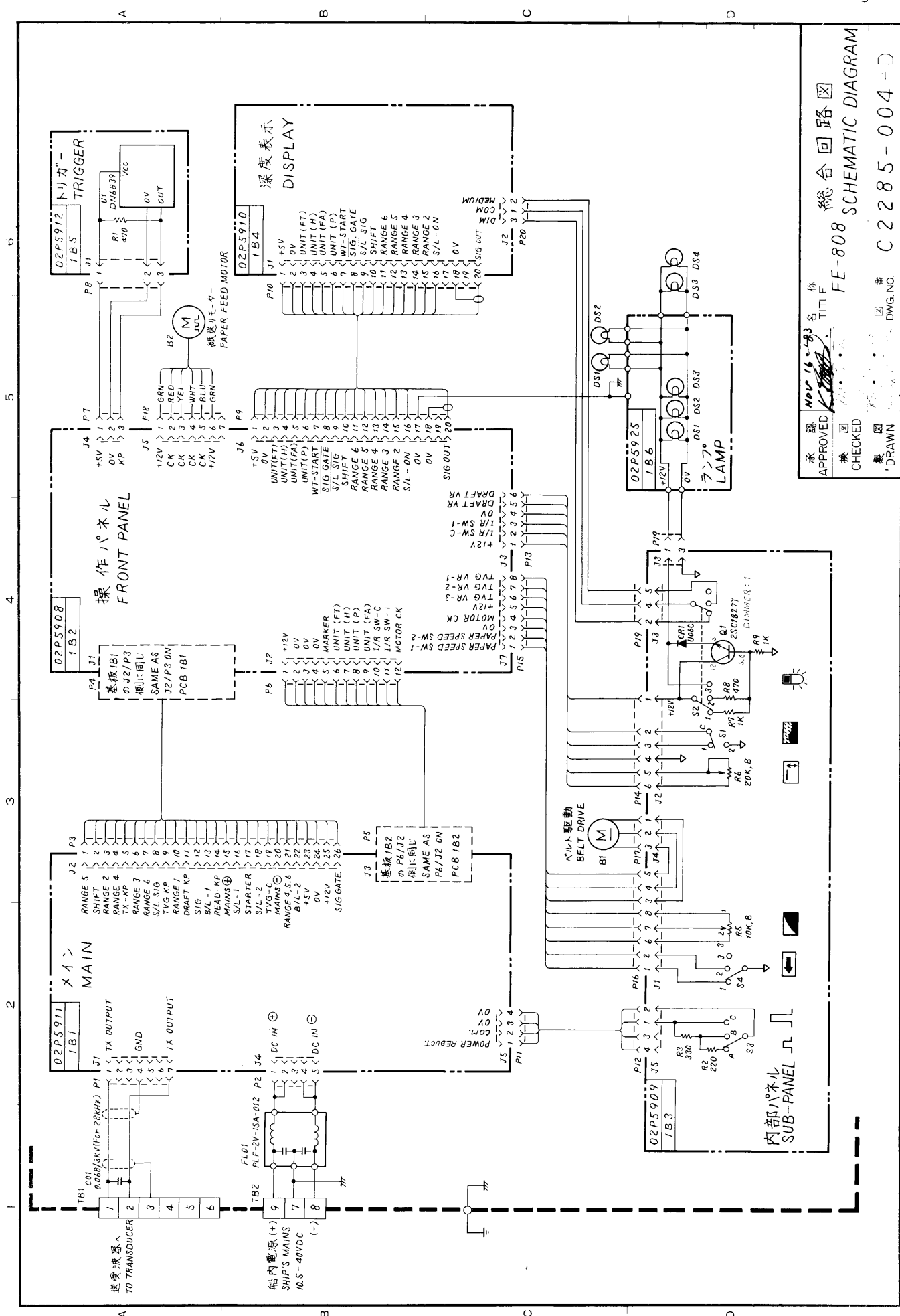

承認 *Nov 16 '83* 名称 総合回路図
 APPROVED TITLE FE-808 SCHEMATIC DIAGRAM
 検 査 CHECKED
 製 造 番号 C 2 2 8 5 - 0 0 4 - D
 'DRAWN

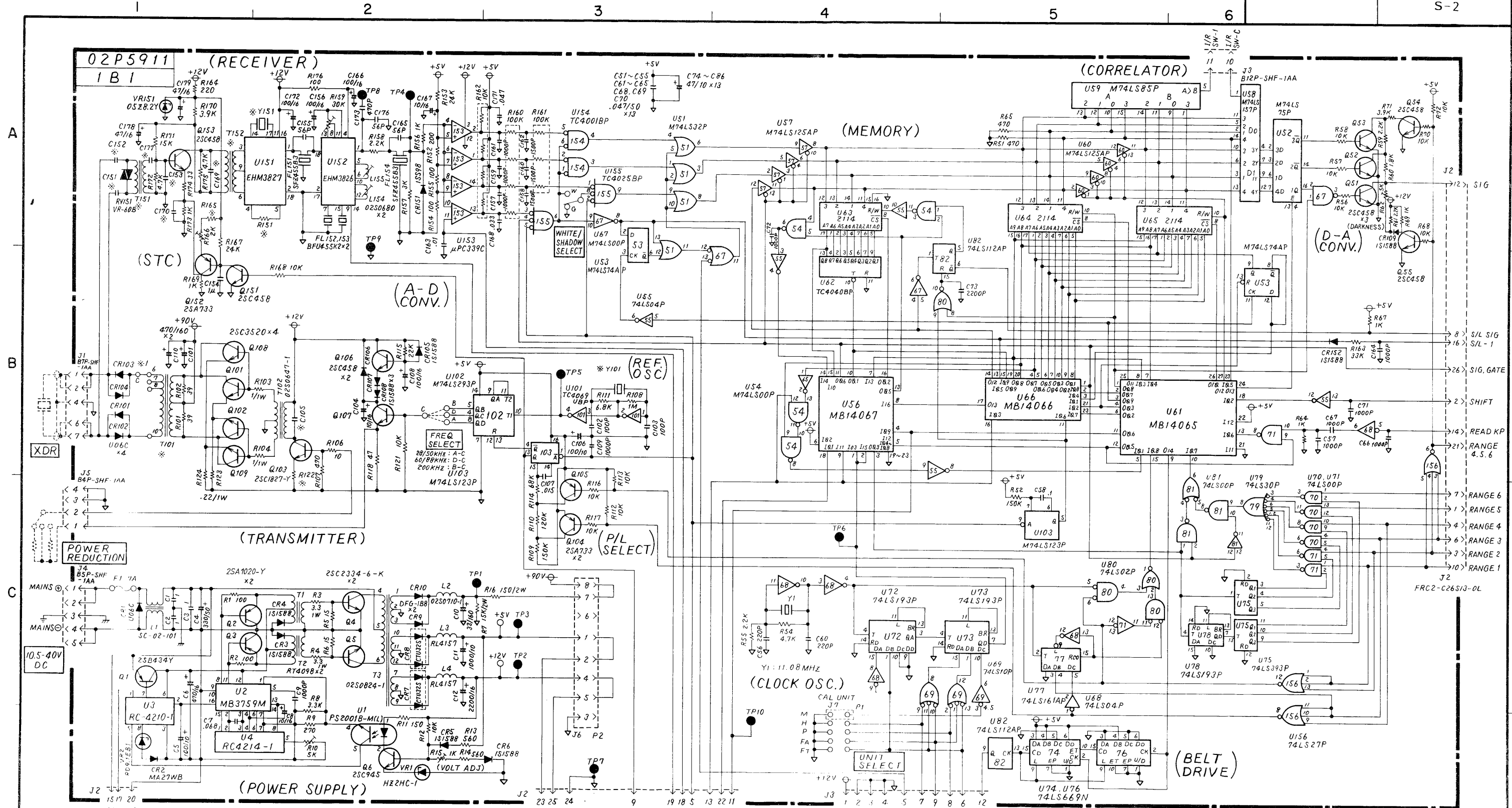

NOTE 1. *印の部品の定数、型は送振周波数により異なる。下表参照。
 COMPONENTS MARKED * DEPENDENT ON SYSTEM FREQUENCY. SEE TABLE BELOW.

	C105	C151, C152	C153	C169	C170	C177	T101	T151	T152	R122	R151	R165	Y101	Y151	*1 (STANDARD)	*1 (OPTION)
28KHz	1.0μF	0.0058μF	0.01μF	3900PF	0.1μF	0.1μF	02S0880	02S0826	02S0829	1/1W	1K	5.6K	461KHz	484KHz	7 C(28F 8)	8 C(28F 18)
50KHz	0.33μF	0.0033μF	2200PF	1800PF	0.1μF	0.1μF	02S0881	02S0827	02S0830	1/1W	1K	5.6K	800KHz	505KHz	7 C(50B 4)	8 C(50B 9)
60KHz	0.33μF	0.0027μF	1500PF	1500PF	0.1μF	0.1μF	02S0869	02S0872	02S0875	22/1W	1K	5.6K	496KHz	517KHz	6 C(60B-5S)	7 C(60B 52)
88KHz	0.33μF	0.0015μF	1000PF	1000PF	0.1μF	0.1μF	02S0871	02S0871	02S0875	1/1W	1K	5.6K	704KHz	543KHz	6 C(88B 8)	7 C(88B 10)
200KHz	0.047μF	0.001μF	470PF	470PF	0.0022μF	0.01μF	02S0882	02S0828	02S0831	0.22/1W	100	4.3K	800KHz	655KHz	6 C(200B 5S)	7 C(200B 8)

2. 特記なき抵抗の値はΩ (1/4W), コンデンサの容量はμF.
 ALL RESISTANCE IN OHMS (1/4W) AND CAPACITANCE IN MICROFARADS UNLESS NOTED OTHERWISE.

承認 APPROVED	Nov. 10 1973	名称 TITLE	FE-808 メイン基板 MAIN BOARD
検 CHECKED		図番 DWG. NO.	C2285-005-E
製 DRAWN			

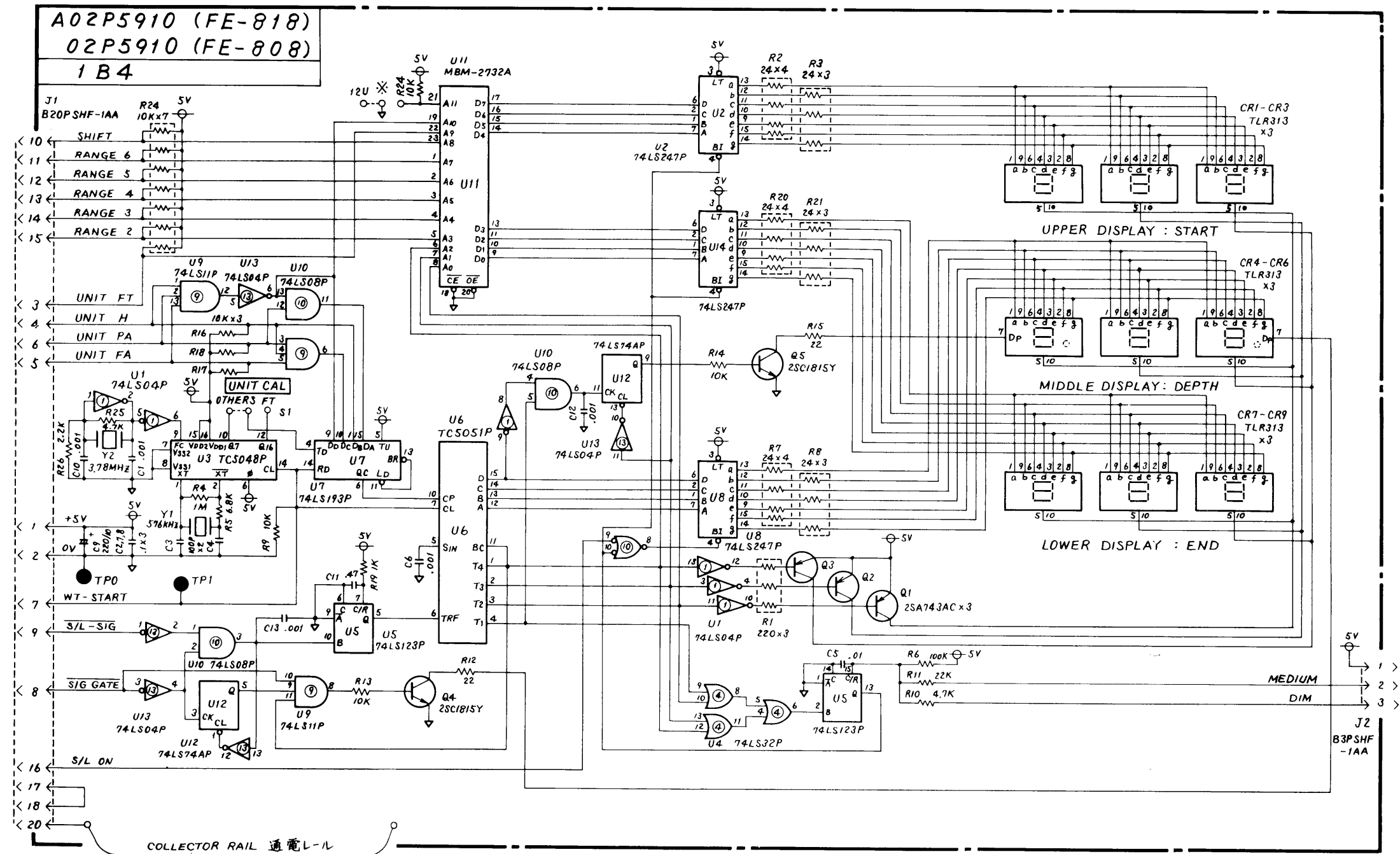

NOTE 1. 特記無き抵抗の値はΩ(1/4W)、コンデンサの容量はμF.
 ALL RESISTANCE IN OHMS (1/4W) AND CAPACITANCE IN MICROFARADS UNLESS NOTED OTHERWISE.

2. ※ジャンパー-接続 JUMPER CONNECTION.
 FE-808---- 12U AND COMMON
 FE-818---- R24 AND COMMON

品番 ITEM	品名 NAME	材質 MATERIAL	数量 Q.TY	図番 DWG.NO.	摘要 REMARKS
承認 APPROVED	三角法 THIRD ANGLE PROJECTION				名称 TITLE FE-808 深度表示基板 818 DISPLAY BOARD
検閲 CHECKED	尺度 SCALE				図番 DWG.NO. C2285-008-D
製図 DRAWN	重量 WEIGHT	kg			

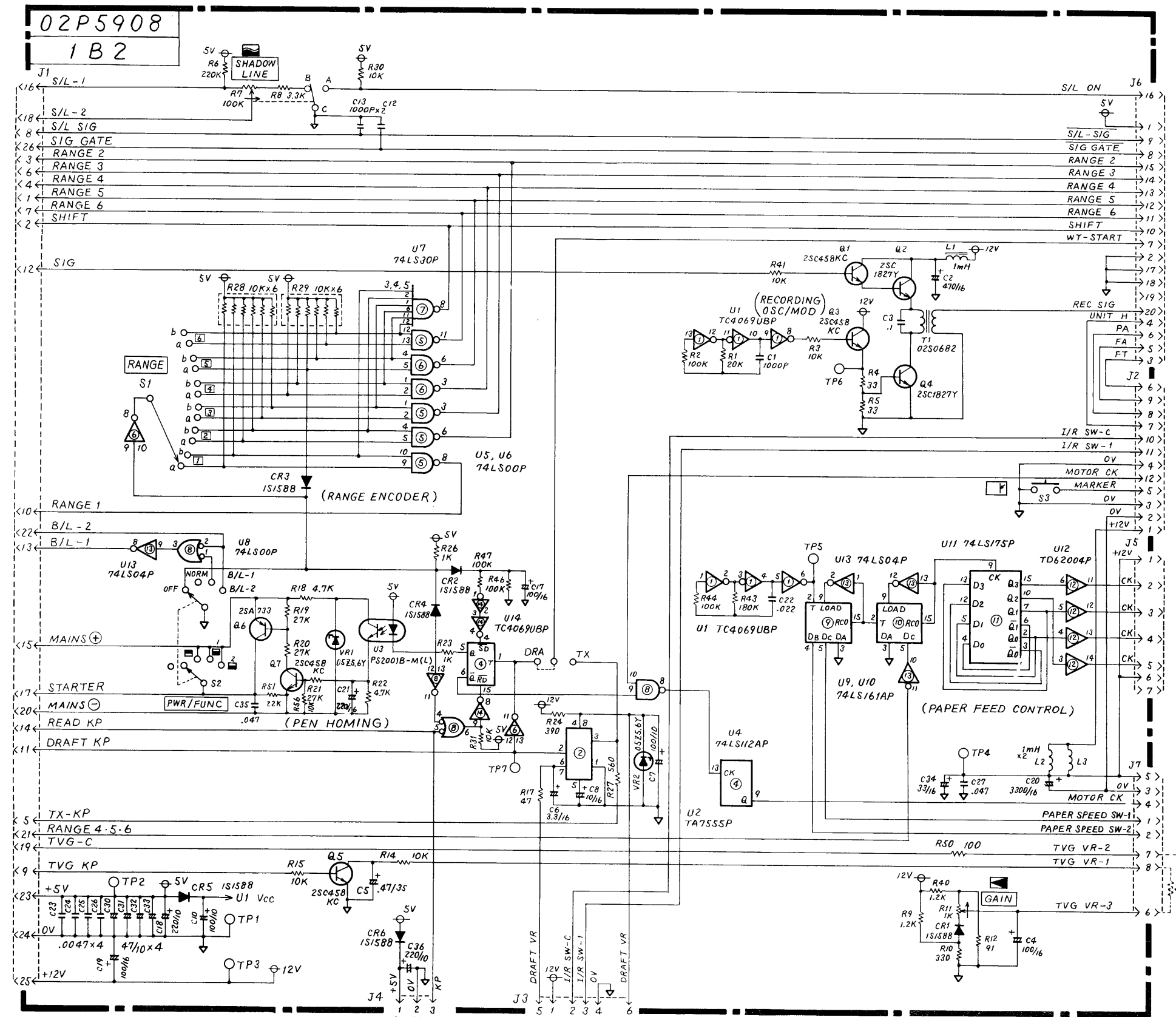

NOTE 1. 特記無き抵抗の値は Ω (1/4W). コンデンサの容量は μ F.
 ALL RESISTANCE IN OHMS (1/4W) AND CAPACITANCE IN MICROFARADS
 UNLESS NOTED OTHERWISE.

ITEM	NAME	MATERIAL	QTY	DWG. NO.	REMARKS
承認 APPROVED	Nov. 11. 83	三角法 THIRD ANGLE PROJECTION			名称 TITLE FE-808 操作パネル基板 FRONT PANEL BOARD
検閲 CHECKED	Nov. 11. 83	尺度 SCALE			図番 DWG. NO. C2285-009-C
製図 DRAWN	11TH. 83	重量 WEIGHT	kg		